

# CONSTRUCTION DRAWINGS OF NEW BRIDGE CREEK

## A 35 LOT RESIDENTIAL SUBDIVISION

### MOYOCK TOWNSHIP CURRITUCK COUNTY NORTH CAROLINA

### SHEET INDEX

**DEVELOPMENT NOTES:**

1. TOTAL PROJECT AREA:	99.67 AC.
TOTAL PROPERTY AREA:	104.09 AC.
TOTAL ACE WETLANDS:	47.51 AC.
TOTAL CAMA WETLANDS:	4.42 AC.
2. DEVELOPMENT SUMMARY	
PROPOSED LOT AREA:	124.71 AC.
PROPOSED R/W AREA:	14.36 AC.
PROPOSED OPEN SPACE AREA:	170.60 AC.
# OF PROPOSED SINGLE FAMILY LOTS:	35
PROPOSED RIGHT-OF-WAY WIDTH:	50' TYP.
PROPOSED PAVED ROADWAY WIDTH:	20' TYP.
LINEAR FEET OF SUBDIVISION ROADWAY:	13,823 LF.
3. IMPERVIOUS COVERAGE DATA (BUA):	
MAXIMUM TOTAL LOT COVERAGE:	260,990 SF
ROADWAY:	77,797 SF
PARKING:	6,432 SF
SIDEWALKS:	41,534 SF
MISC. AMENITIES:	4,636 SF
TOTAL COVERAGE:	400,389 SF (9.2%)
4. DISTURBED AREA SUMMARY:	
PROPERTY AREA DISTURBED:	35.58 AC±
R/W AREA DISTURBED:	4.36 AC±
OFFSITE AREA DISTURBED:	0.98 AC±
TOTAL DISTURBED AREA:	40.92 AC±

**GENERAL NOTES:**

- PROJECT NAME: NEW BRIDGE CREEK CONSERVATION SUBDIVISION
- OWNER/APPLICANT: NEW BRIDGE CREEK, LLC  
C/O JERRY OLD, AGENT  
101 OAK STREET  
MOYOCK, NC 27558
- PROPERTY DATA:  
PARCEL ID# 0031-0000-640-0000, 0031-0000-64C-0000, 0031-0000-64K-0000,  
0031-0000-64L-0000, 0031-0000-64M-0000 & 0031-0000-64N-0000  
PRIMARY ADDRESS: CARATOKE HWY., MOYOCK, NC  
RECORDED REFERENCES: D.B. 1491, PG. 790, P.C. 0, SL. 168  
PROPERTY ZONING: AG - AGRICULTURAL
- F.I.R.M. DATA:  
ZONES X, SHADED X & AE (4') PER F.E.M.A. F.I.R.M. MAP NUMBER 3721804000 K, EFFECTIVE DATE  
DECEMBER 21, 2018. USE OF LAND WITHIN A FLOODWAY OR FLOOD PLAIN IS SUBSTANTIALLY RESTRICTED  
BY CHAPTER 7 OF THE CURRITUCK COUNTY UNIFIED DEVELOPMENT ORDINANCE.
- THIS PROPERTY CONTAINS ACCE "404" JURISDICTIONAL WETLANDS AS SHOWN AND CONFIRMED BY USACE ACTION  
ID# SAW 2018-00505, DATED SEPTEMBER 7, 2018, AND MAY REQUIRE U.S. CORP OF ENGINEERS APPROVAL PRIOR  
TO DEVELOPMENT OF THE PROPERTY.
- A 10' EASEMENT FOR UTILITIES AND DRAINAGE ALONG REAR AND SIDE PROPERTY LINES AND A 20' EASEMENT  
FOR UTILITIES, DRAINAGE, WALKWAYS & STREET TREES ALONG FRONT PROPERTY LINE IS HEREBY ESTABLISHED.
- A DRAINAGE EASEMENT SHALL BE ESTABLISHED ALONG ALL MAJOR DRAINAGE WAYS SERVING MORE THAN 5  
ACRES, THAT INCLUDES THE CONVEYANCE PLUS 25' FROM THE TOP OF BANK. A BLANKET DRAINAGE, UTILITY,  
AND PEDESTRIAN ACCESS EASEMENT IS HEREBY ESTABLISHED ACROSS ALL OPEN SPACE AREAS.
- EXISTING CONDITION INFORMATION BASED ON A COMBINATION OF THE FOLLOWING:  
• 2012 AERIAL IMAGERY OBTAINED FROM NCONEMAP.COM  
• FIELD TOPOGRAPHIC SURVEY DATA BY LIDAR OBTAINED FROM NC FLOOD RISK INFORMATION SYSTEM.  
• LAND DEVELOPMENT PLANS BY QUILBE & ASSOCIATES, P.C., COMMISSION # P17079,  
DATED 09/13/19.  
• ELEVATIONS ARE REFERENCED TO NAVD 1988 VERTICAL DATUM.
- SECTION 7.6.5 OF THE CURRITUCK U.D.O. SUBSTANTIALLY RESTRICTS DEVELOPMENT WITHIN A 30' RIPARIAN  
BUFFER.
- ALL UTILITIES ARE TO BE UNDERGROUND.
- NEAREST HYDRANT (MEC21) FLOW TESTED AT 839 GPM. DESIGN FIRE FLOW IS 500 GPM FOR SINGLE FAMILY  
RESIDENCES BASED ON STRUCTURES HAVING LESS THAN 4,800 SQ. FT. AND NOT OVER 2-STORIES HIGH. NFF  
FOR MULTI-FAMILY STRUCTURES IS BASED ON ISO STANDARDS.



**SURVEY LEGEND**

SCM	SET CONCRETE MONUMENT
ECM	EXISTING CONCRETE MONUMENT
SIR	SET IRON ROD
EIR	EXISTING IRON ROD
EIP	EXISTING IRON PIPE
CP	CALCULATED POINT
M.B.L.	MAXIMUM BUILDING LIMIT
N.T.S.	NOT TO SCALE
P.C.	PLAT CABINET
D.B.	DEED BOOK
SL	SLIDE
SF	SQUARE FEET
AC	ACRES

STORMWATER CERTIFICATE

I, \_\_\_\_\_, OWNER/AGENT HEREBY CERTIFY THE INFORMATION INCLUDED ON THIS AND ATTACHED PAGES IS TRUE AND CORRECT TO THE BEST OF MY KNOWLEDGE.

ON THE PLAN ENTITLED, CONSTRUCTION DRAWINGS OF NEW BRIDGE CREEK - A 35 LOT RESIDENTIAL SUBDIVISION, STORMWATER DRAINAGE IMPROVEMENTS SHALL BE INSTALLED ACCORDING TO THESE PLANS AND SPECIFICATIONS AND APPROVED BY CURRITUCK COUNTY. YEARLY INSPECTIONS ARE REQUIRED AS PART OF THE STORMWATER PLAN. THE OWNER IS RESPONSIBLE FOR ALL MAINTENANCE REQUIRED. CURRITUCK COUNTY ASSUMES NO RESPONSIBILITY FOR THE DESIGN, MAINTENANCE, OR PERFORMANCE OF THE STORMWATER IMPROVEMENTS.

DATE \_\_\_\_\_ OWNER/AGENT \_\_\_\_\_

FINAL DESIGN  
NOT RELEASED FOR  
CONSTRUCTION

**CIVIL LEGEND**

EXISTING		NEW
○	MANHOLE	⊙
□	SANITARY CLEANOUT	■
◇	VALVE	●
⊕	WATER METER	⊕
⊕	FIRE HYDRANT	⊕
⊕	WELL	⊕
⊕	DROP INLET	⊕
⊕	CURB INLET	⊕
⊕	GAS METER	⊕
⊕	POWER POLE	⊕
⊕	LIGHT POLE	⊕
⊕	LIGHT POLE /CONCRETE BASE	⊕
⊕	PEDESTAL	⊕
=====	CURB AND GUTTER	=====
-x-x-x-	FENCE	-x-x-x-
=====	PROPERTY LINE	=====
=====	BUILDINGS	=====
---ST---	STORM SEWER	---ST---
---SS---	SANITARY SEWER	---SS---
---W---	WATER	---W---
---OHT---	ELECTRIC & TELEPHONE LINE	---OHT---
---UGT---	TRAFFIC BOX	---UGT---
○	SIGN	○
○	TREE	○
○	BUSH	○
	PAVEMENT	
	CONCRETE	
⊕	TEMPORARY BENCHMARK (TBM)	⊕
10.00	ELEVATIONS	10.00
TC 10.50	TOP OF CURB ELEVATIONS	TC 10.50
10.00		10.00
TW 10.50	TOP OF WALK ELEVATIONS	TW 10.50
10.00		10.00
---	TOP OF BANK	---
---	TOP OF SLOPE	---
---	OF DITCH	---
---	OF SWALE	---

C-001	TITLE SHEET
C-002	EXISTING CONDITIONS
C-003	MASTER SHEET INDEX
CD101	DEMOLITION, EROSION & SEDIMENT CONTROL PLAN (PHASE 1)
CD102	DEMOLITION, EROSION & SEDIMENT CONTROL PLAN (PHASE 2)
CD103	DEMOLITION, EROSION & SEDIMENT CONTROL PLAN (PHASE 3)
CG101	MASTER GRADING & DRAINAGE PLAN
CG102	MASTER GRADING & DRAINAGE PLAN
CG103	MASTER GRADING & DRAINAGE PLAN
CG104	MASTER GRADING & DRAINAGE PLAN
CG105	MASTER GRADING & DRAINAGE PLAN
CS101	MASTER LAYOUT & UTILITY PLAN
CS102	MASTER LAYOUT & UTILITY PLAN
CS103	MASTER LAYOUT & UTILITY PLAN
CS104	MASTER LAYOUT & UTILITY PLAN
CS105	MASTER LAYOUT & UTILITY PLAN
CL101	LANDSCAPING, LIGHTING & SIGNAGE PLAN
CP101	PLAN & PROFILE
CP102	PLAN & PROFILE
CP103	PLAN & PROFILE
CP104	PLAN & PROFILE
CP105	PLAN & PROFILE
CP106	PLAN & PROFILE
CP107	PLAN & PROFILE
CP108	PLAN & PROFILE
CP109	PLAN & PROFILE
C-501	DETAILS
C-502	DETAILS
C-503	E&S CONTROL NOTES & DETAILS
C-504	E&S CONTROL AND MISCELLANEOUS DETAILS
C-505	NCG01-GROUND STABILIZATION & MATERIALS HANDLING
C-506	NCG01-SELF INSPECTION, RECORDKEEPING & REPORTING

THE FOLLOWING PERMITS ARE REQUIRED PRIOR TO PROJECT CONSTRUCTION:

PERMIT	AGENCY	REFERENCE NUMBER	DATE OF ISSUANCE
SEDIMENTATION AND EROSION CONTROL PERMIT	N.C.D.E.Q. - DIVISION OF LAND RESOURCES	-	-
STORMWATER MANAGEMENT PERMIT	N.C.D.E.Q. - DIVISION OF LAND RESOURCES	-	-
WATERLINE EXTENSION AUTHORIZATION TO CONSTRUCT	N.C.D.E.Q. - PUBLIC WATER SUPPLY	-	-
DRIVEWAY PERMIT	NCDOT	-	-
ENCROACHMENT AGREEMENT	NCDOT	-	-
CURRITUCK COUNTY PRELIMINARY PLAT & USE PERMIT	CURRITUCK COUNTY BOARD OF COMMISSIONERS	-	-
CURRITUCK COUNTY CONSTRUCTION AUTHORIZATION	CURRITUCK COUNTY PLANNING STAFF	-	-

North Carolina  
**One-Call Center** Inc.

811

Know what's below  
Call before you dig.

A STORMWATER MAINTENANCE AND ACCESS EASEMENT ACROSS ALL OPEN SPACE IS TO BE GRANTED TO WILSON RIDGE HOMEOWNERS ASSOCIATION AND TO NORTH CAROLINA DEPARTMENT OF ENVIRONMENTAL QUALITY (NCDEQ). NCDEQ WILL NOT ASSUME RESPONSIBILITY FOR MAINTENANCE OF STORMWATER APPURTENANCES. OPERATION AND MAINTENANCE REMAIN THE RESPONSIBILITY OF THE WILSON RIDGE HOMEOWNERS ASSOCIATION, THEIR SUCCESSORS AND ASSIGNS.

NOTE:  
EXISTING SITE INFORMATION DESCRIBED HEREON IS BELIEVED TO BE ACCURATE. HOWEVER, BPG INC. MAKES NO WARRANTY AS TO THE ACCURACY. IT IS THE CONTRACTORS RESPONSIBILITY TO VERIFY THIS INFORMATION BEFORE RELYING ON IT. THE CONTENT OF THESE DOCUMENTS MAY ALSO INCLUDE TECHNICAL INACCURACIES OR TYPOGRAPHICAL ERRORS. IF SUCH CONDITIONS EXIST, THE CONTRACTOR SHALL CONSULT WITH THE ENGINEER PRIOR TO PROCEEDING WITH THE SCHEDULED WORK AND MAY CONTINUE AFTER AN AUTHORIZATION TO PROCEED HAS BEEN GRANTED.

**MSA**

ENGINEERS | SCIENTISTS | SURVEYORS

5032 ROUSE DRIVE, SUITE 200 | VIRGINIA BEACH, VA 23462 | 757.490.9264 | MSAONLINE.COM

THIS DOCUMENT IS THE SOLE PROPERTY OF MSA, P.C., VIRGINIA BEACH, VIRGINIA. THE REPRODUCTION IN WHOLE OR IN PART, THE MODIFICATION OF ANY DETAIL OR DESIGN, OR USE FOR ANY PURPOSE OTHER THAN THAT INTENDED BY MSA, P.C., MAY NOT BE MADE WITHOUT THE EXPRESSED WRITTEN CONSENT OF MSA, P.C.

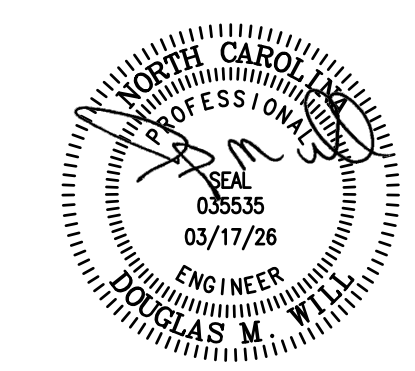

PLAN STATUS			NEW BRIDGE CREEK
DATE	INITIAL	DESCRIPTION	
06/11/2025	JTP	1st SUBMITTAL	C-001
01/08/2026	DMW	2nd SUBMITTAL	
03/17/2026	DMW	3rd SUBMITTAL	
1 of 33 Sheets			PROJ. NO.: 24102

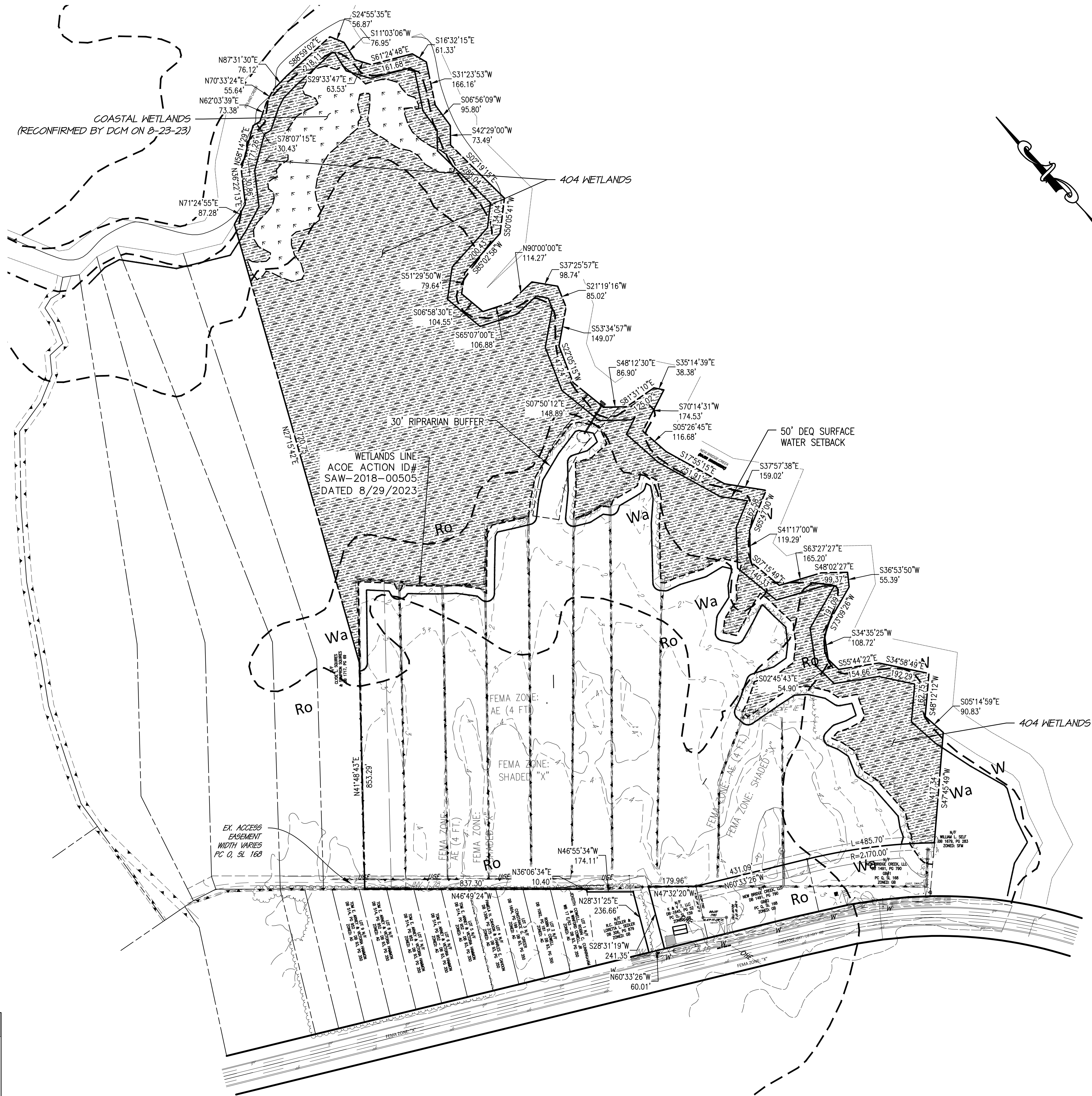

SOILS LEGEND	
---	SOILS LINE
Ro	ROANOKE FINE SANDY LOAM
Wa	WAAHEE FINE SANDY LOAM

**FINAL DESIGN  
NOT RELEASED FOR  
CONSTRUCTION**

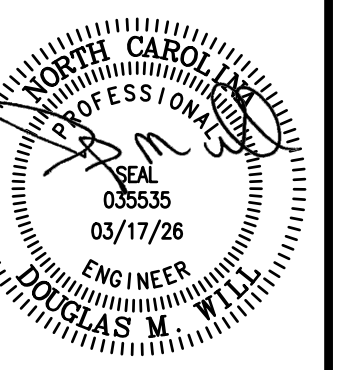
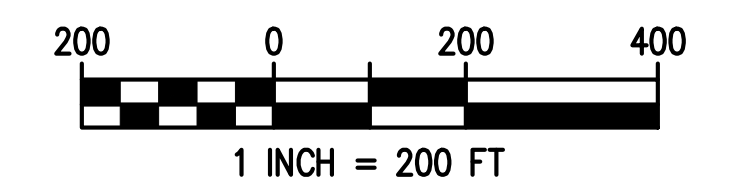

DESIGNED	ENL
DRAWN	JTP
CHECKED	DMW
APPROVED	DMW
DATE	03/17/26

REVISION	DATE	BY	DESCRIPTION

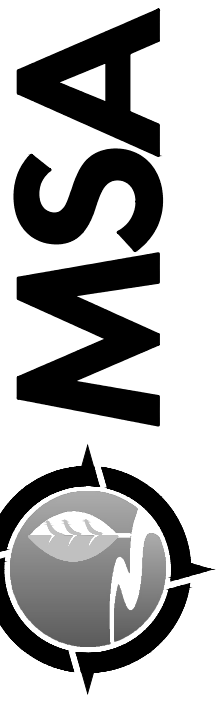
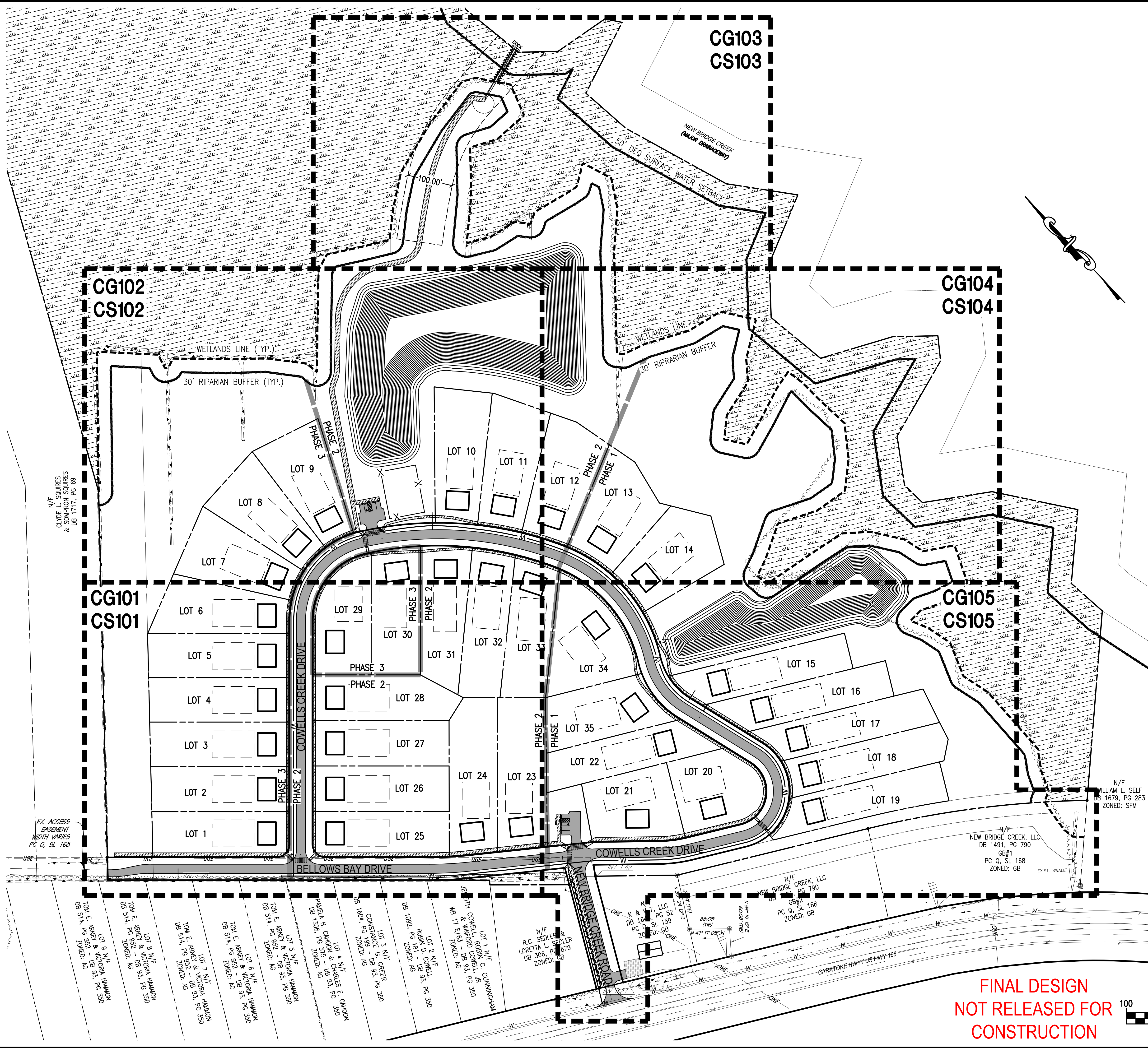

ENGINEERS | SCIENTISTS | SURVEYORS

5032 ROUSE DRIVE, SUITE 200 | VIRGINIA BEACH, VA 23462 | 757.490.9264 | MSAONLINE.COM

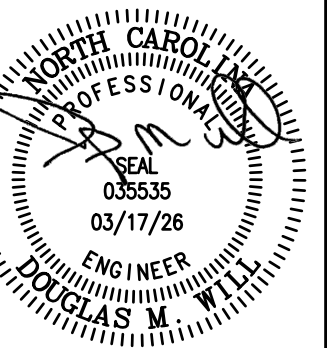

DESIGNED	ENL	JTP	DMW	DMW	DATE
DRAWN					03/17/26
CHECKED					
APPROVED					

REVISION	DATE	BY	DESCRIPTION

SHEET INDEX OF  
**NEW BRIDGE CREEK**  
CURRITUCK COUNTY, NORTH CAROLINA  
MOTOCK TOWNSHIP

SHEET  
**C-003**  
3 of 32 Sheets  
SCALE: 1" = 100'  
PROJ. NO.: 24102

**GENERAL NOTES:**

- NEW BRIDGE CREEK SUBDIVISION IS TO BE CONSTRUCTED IN THREE PHASES. PHASES ARE DENOTED ON THE PLANS.
- ALL MATERIALS EXCAVATED OVER THE COURSE OF CONSTRUCTION SHALL REMAIN ON THE PROJECT SITE. THIS MATERIAL SHALL BE USED FOR FILLING EXISTING DITCHES, CONSTRUCTION OF ROADWAYS AND PREPARING THE RESIDENTIAL LOTS AS ILLUSTRATED ON THE GRADING PLANS. IF NECESSARY, EXCAVATED MATERIALS REMAINING AT THE END OF CONSTRUCTION MAY BE DISPOSED OF OFF-SITE AT AN APPROVED AND PERMITTED BORROW PIT.
- OFF-SITE BORROW, IF NECESSARY, MUST BE OBTAINED FROM AN APPROVED AND PERMITTED BORROW PIT.
- NO GREATER THAN 20 ACRES OF LAND SHALL BE DISTURBED AT ONE TIME. CONSTRUCTION AND STABILIZATION ACTIVITIES SHALL, TO THE MAXIMUM EXTENT PRACTICABLE, BE SCHEDULED ACCORDINGLY.
- THE FOLLOWING PROVIDES AN ESTIMATED MATERIAL BALANCE OF THIS PROJECT:  
 APPROXIMATE CUT VOLUME: **75,835 CY±**  
 APPROXIMATE FILL VOLUME: **69,418 CY±**
- \*THE VALUES ARE GROSS ESTIMATES AND ARE PROVIDED FOR PERMITTING PURPOSES ONLY. COMPACTION AND SUITABILITY OF SOILS FOR USE IN CONSTRUCTION ARE NOT CONSIDERED AND ADDITIONAL MATERIAL MAY BE NECESSARY. CONTRACTORS SHALL NOT RELY UPON THESE ESTIMATES AND SHOULD DETERMINE THEIR OWN MATERIAL NEEDED FOR CONSTRUCTION.

**SEDIMENT BASIN NOTE:**

DURING CONSTRUCTION, POND #1 & POND #2 SHALL BE UTILIZED AS AN EROSION & SEDIMENT CONTROL SEDIMENT BASIN. AFTER CONSTRUCTION IS COMPLETE AND THE SITE IS PROPERLY STABILIZED THE POND SHALL BE CLEANED AND RESTORED TO ITS DESIGN SPECIFICATIONS AND THE BANKS PERMANENTLY STABILIZED WITHIN 7 DAYS.

**EXISTING DITCH FILL NOTE:**

EXISTING DITCHES NOTED AS BEING FILLED SHALL BE DEMUCKED AND BACKFILLED WITH CLEAN, COMPACTED SELECT MATERIAL. DITCH FILLING SHALL COINCIDE WITH DRAINAGE PATTERNS AND EROSION CONTROL MEASURES AS PROVIDED IN THESE PLANS.

**STOCKPILE AREA NOTE:**

PLACEMENT OF EXCAVATED MATERIAL EITHER DIRECTLY ON THE LOTS OR IN A STOCKPILE WILL BE AT THE DISCRETION OF THE CONTRACTOR. ALL STOCKPILES SHALL INCORPORATE EROSION CONTROL MEASURES IN ACCORDANCE WITH NCDEQ REQUIREMENTS.

**DEMOLITION KEYNOTES:**

- REMOVE TREES, CLEAR & GRUB
- REMOVE HYDRANT. CAP AND ABANDON HYDRANT SERVICE LINE.
- DE-MUCK AND BACKFILL DITCH
- \*COORDINATE WITH DOMINION POWER FOR RELOCATION OF POWER POLE AND UNDERGROUND CONDUIT PLACEMENT
- PROPOSED 74 LF 18" CLASS V RCP (REFER TO SHEET CG101 FOR STORM SCHEDULE AND SHEET CG105 FOR PLAN DETAIL)
- PROPOSED 48 LF 18" CLASS V RCP (REFER TO SHEET CG101 FOR STORM SCHEDULE AND SHEET CG105 FOR PLAN DETAIL)

**EROSION CONTROL LEGEND**

DESCRIPTION	SYMBOL
SILT FENCE (DENOTES LOD)	X (SF)
CONSTRUCTION ENTRANCE	CE
TREE PROTECTION	TP
CHECK DAM	CD

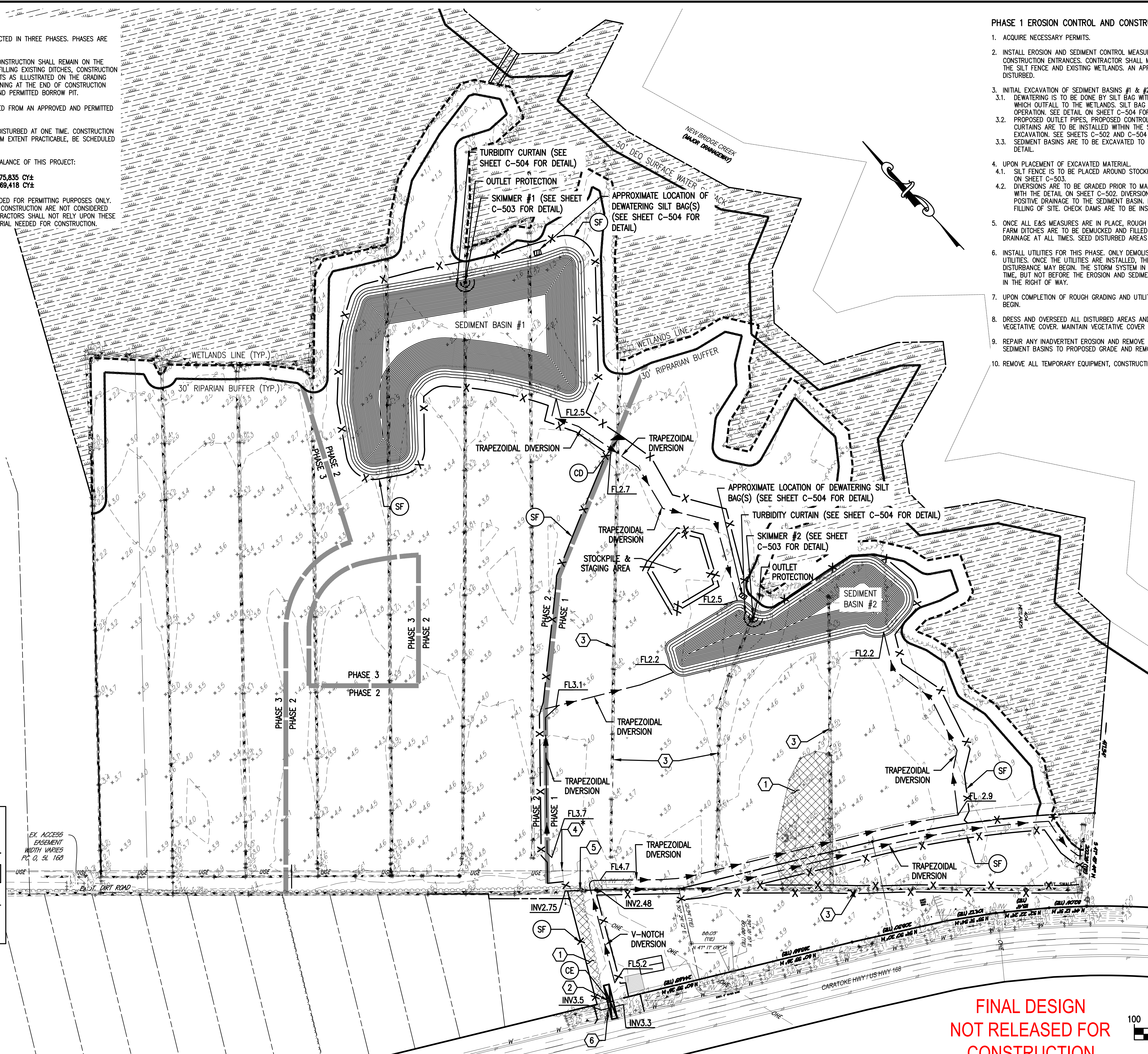

**PHASE 1 EROSION CONTROL AND CONSTRUCTION SEQUENCING:**

- ACQUIRE NECESSARY PERMITS.
- INSTALL EROSION AND SEDIMENT CONTROL MEASURES CONSISTING INITIALLY OF SILT FENCE AND CONSTRUCTION ENTRANCES. CONTRACTOR SHALL MAINTAIN A MINIMUM 3' SEPARATION BETWEEN THE SILT FENCE AND EXISTING WETLANDS. AN APPROXIMATE TOTAL OF 20.00 ACRES ARE TO BE DISTURBED.
- INITIAL EXCAVATION OF SEDIMENT BASINS #1 & #2.
  - DEWATERING IS TO BE DONE BY SILT BAG WITH RUNOFF DIRECTED TO EXISTING DITCHES WHICH OUTFALL TO THE WETLANDS. SILT BAG IS TO BE CONTINUOUSLY MONITORED DURING OPERATION. SEE DETAIL ON SHEET C-504 FOR DETAIL.
  - PROPOSED OUTLET PIPES, PROPOSED CONTROL STRUCTURES, SKIMMERS, AND TURBIDITY CURTAINS ARE TO BE INSTALLED WITHIN THE SEDIMENT BASINS CONCURRENTLY WITH EXCAVATION. SEE SHEETS C-502 AND C-504 FOR DETAIL.
  - SEDIMENT BASINS ARE TO BE EXCAVATED TO PROPOSED GRADE. SEE SHEET C-502 FOR DETAIL.
- UPON PLACEMENT OF EXCAVATED MATERIAL.
  - SILT FENCE IS TO BE PLACED AROUND STOCKPILE AREAS IN ACCORDANCE WITH THE DETAIL ON SHEET C-503.
  - DIVERSIONS ARE TO BE GRADED PRIOR TO MATERIAL PLACEMENT ON LOTS IN ACCORDANCE WITH THE DETAIL ON SHEET C-502. DIVERSION DIKES ARE TO BE GRADED TO PROVIDE POSITIVE DRAINAGE TO THE SEDIMENT BASIN. DIVERSION DEPTHS WILL BE VARIABLE DUE TO FILLING OF SITE. CHECK DAMS ARE TO BE INSTALLED WITHIN EXISTING DITCHES.
- ONCE ALL E&S MEASURES ARE IN PLACE, ROUGH GRADE IN ACCORDANCE WITH PLANS. EXISTING FARM DITCHES ARE TO BE DEMUCKED AND FILLED IN A MANNER TO MAINTAIN TEMPORARY DRAINAGE AT ALL TIMES. SEED DISTURBED AREAS IMMEDIATELY AFTER GRADING.
- INSTALL UTILITIES FOR THIS PHASE. ONLY DEMOLISH AND DISTURB AREAS NEEDED TO INSTALL UTILITIES. ONCE THE UTILITIES ARE INSTALLED, THE REMAINING DEMOLITION ITEMS AND DISTURBANCE MAY BEGIN. THE STORM SYSTEM IN THE RIGHT OF WAY MAY BE INSTALLED AT ANY TIME, BUT NOT BEFORE THE EROSION AND SEDIMENT CONTROL MEASURES HAVE BEEN INSTALLED IN THE RIGHT OF WAY.
- UPON COMPLETION OF ROUGH GRADING AND UTILITY INSTALLATION, PAVING OPERATIONS MAY BEGIN.
- DRESS AND OVERSEED ALL DISTURBED AREAS AND IMMEDIATELY ESTABLISH PERMANENT VEGETATIVE COVER. MAINTAIN VEGETATIVE COVER THROUGHOUT DURATION OF PROJECT.
- REPAIR ANY INADVERTENT EROSION AND REMOVE ANY INADVERTENT SEDIMENTATION. CLEANOUT SEDIMENT BASINS TO PROPOSED GRADE AND REMOVE SKIMMERS.
- REMOVE ALL TEMPORARY EQUIPMENT, CONSTRUCTION MATERIALS AND DEBRIS FROM THE SITE.

C:\Users\ETI\OneDrive\Documents\Projects\New Bridge Creek\Temp\New Bridge Creek.dwg [CD101] - Friday, April 03, 2020, 4:49pm

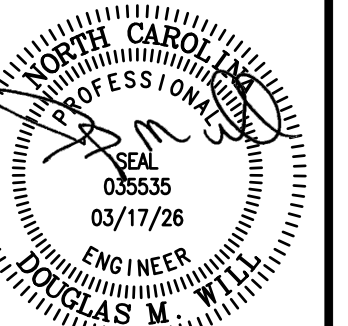

DESIGNED	ENL	DATE	03/17/26
DRAWN	ENL		
CHECKED	DMW		
APPROVED	DMW		

REVISION	DATE	BY	DESCRIPTION

DEMOLITION, EROSION & SEDIMENT CONTROL PLAN (PHASE 1)  
 OF  
**NEW BRIDGE CREEK**  
 CURRITUCK COUNTY, NORTH CAROLINA

SHEET  
**CD101**  
 4 of 32 Sheets  
 SCALE: 1" = 100'  
 PROJ. NO.: 24102

**FINAL DESIGN  
 NOT RELEASED FOR  
 CONSTRUCTION**

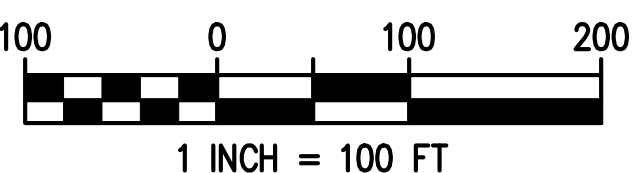

**GENERAL NOTES:**

1. NEW BRIDGE CREEK SUBDIVISION IS TO BE CONSTRUCTED IN THREE PHASES. PHASES ARE DENOTED ON THE PLANS.
2. ALL MATERIALS EXCAVATED OVER THE COURSE OF CONSTRUCTION SHALL REMAIN ON THE PROJECT SITE. THIS MATERIAL SHALL BE USED FOR FILLING EXISTING DITCHES, CONSTRUCTION OF ROADWAYS AND PREPARING THE RESIDENTIAL LOTS AS ILLUSTRATED ON THE GRADING PLANS. IF NECESSARY, EXCAVATED MATERIALS REMAINING AT THE END OF CONSTRUCTION MAY BE DISPOSED OF OFF-SITE AT AN APPROVED AND PERMITTED BORROW PIT.
3. OFF-SITE BORROW, IF NECESSARY, MUST BE OBTAINED FROM AN APPROVED AND PERMITTED BORROW PIT.
4. NO GREATER THAN 20 ACRES OF LAND SHALL BE DISTURBED AT ONE TIME. CONSTRUCTION AND STABILIZATION ACTIVITIES SHALL, TO THE MAXIMUM EXTENT PRACTICABLE, BE SCHEDULED ACCORDINGLY.
5. THE FOLLOWING PROVIDES AN ESTIMATED MATERIAL BALANCE OF THIS PROJECT:  
 APPROXIMATE CUT VOLUME: **75,835 CY±**  
 APPROXIMATE FILL VOLUME: **69,418 CY±**
6. \*THE VALUES ARE GROSS ESTIMATES AND ARE PROVIDED FOR PERMITTING PURPOSES ONLY. COMPACTION AND SUITABILITY OF SOILS FOR USE IN CONSTRUCTION ARE NOT CONSIDERED AND ADDITIONAL MATERIAL MAY BE NECESSARY. CONTRACTORS SHALL NOT RELY UPON THESE ESTIMATES AND SHOULD DETERMINE THEIR OWN MATERIAL NEEDED FOR CONSTRUCTION.

**SEDIMENT BASIN NOTE:**

DURING CONSTRUCTION, POND #1 & POND #2 SHALL BE UTILIZED AS AN EROSION & SEDIMENT CONTROL SEDIMENT BASIN. AFTER CONSTRUCTION IS COMPLETE AND THE SITE IS PROPERLY STABILIZED THE POND SHALL BE CLEANED AND RESTORED TO ITS DESIGN SPECIFICATIONS AND THE BANKS PERMANENTLY STABILIZED WITHIN 7 DAYS.

**EXISTING DITCH FILL NOTE:**

EXISTING DITCHES NOTED AS BEING FILLED SHALL BE DEMUCKED AND BACKFILLED WITH CLEAN, COMPACTED SELECT MATERIAL. DITCH FILLING SHALL COINCIDE WITH DRAINAGE PATTERNS AND EROSION CONTROL MEASURES AS PROVIDED IN THESE PLANS.

**STOCKPILE AREA NOTE:**

PLACEMENT OF EXCAVATED MATERIAL EITHER DIRECTLY ON THE LOTS OR IN A STOCKPILE WILL BE AT THE DISCRETION OF THE CONTRACTOR. ALL STOCKPILES SHALL INCORPORATE EROSION CONTROL MEASURES IN ACCORDANCE WITH NCDEQ REQUIREMENTS.

**DEMOLITION KEYNOTES:**

1. REMOVE TREES, CLEAR & GRUB
2. REMOVE HYDRANT. CAP AND ABANDON HYDRANT SERVICE LINE.
3. DE-MUCK AND BACKFILL DITCH
4. \*COORDINATE WITH DOMINION POWER FOR RELOCATION OF POWER POLE AND UNDERGROUND CONDUIT PLACEMENT
5. PROPOSED 74 LF 18" CLASS V RCP (REFER TO SHEET CG101 FOR STORM SCHEDULE AND SHEET CG105 FOR PLAN DETAIL)
6. PROPOSED 48 LF 18" CLASS V RCP (REFER TO SHEET CG101 FOR STORM SCHEDULE AND SHEET CG105 FOR PLAN DETAIL)

**EROSION CONTROL LEGEND**

DESCRIPTION	SYMBOL
SILT FENCE (DENOTES LOD)	X (SF)
CONSTRUCTION ENTRANCE	CE
TREE PROTECTION	TP
CHECK DAM	CD

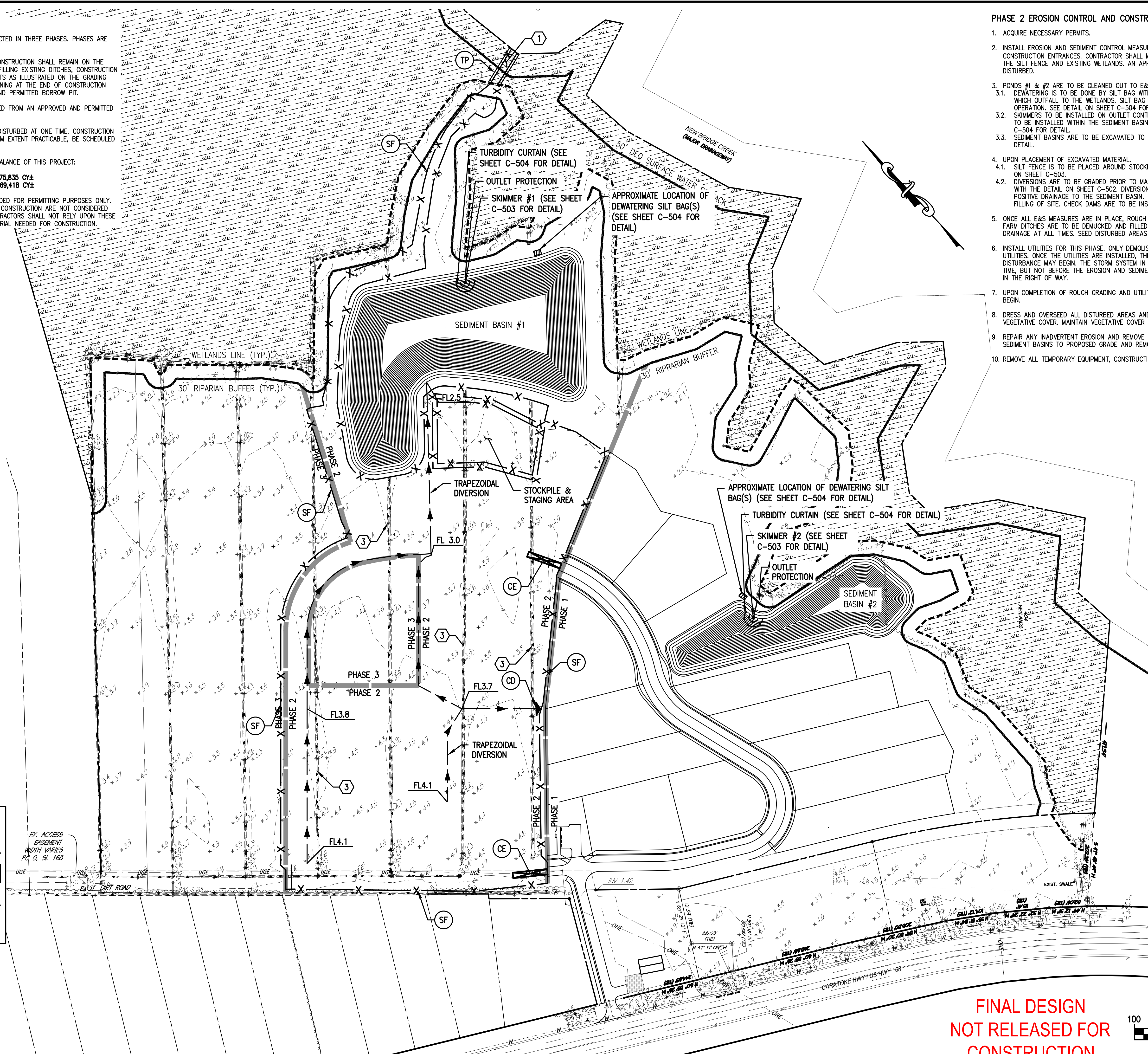

**PHASE 2 EROSION CONTROL AND CONSTRUCTION SEQUENCING:**

1. ACQUIRE NECESSARY PERMITS.
2. INSTALL EROSION AND SEDIMENT CONTROL MEASURES CONSISTING INITIALLY OF SILT FENCE AND CONSTRUCTION ENTRANCES. CONTRACTOR SHALL MAINTAIN A MINIMUM 3' SEPARATION BETWEEN THE SILT FENCE AND EXISTING WETLANDS. AN APPROXIMATE TOTAL OF 12.59 ACRES ARE TO BE DISTURBED.
3. PONDS #1 & #2 ARE TO BE CLEANED OUT TO E&S SEDIMENT BASIN SPECIFICATIONS.
  - 3.1. DEWATERING IS TO BE DONE BY SILT BAG WITH RUNOFF DIRECTED TO EXISTING DITCHES WHICH OUTFALL TO THE WETLANDS. SILT BAG IS TO BE CONTINUOUSLY MONITORED DURING OPERATION. SEE DETAIL ON SHEET C-504 FOR DETAIL.
  - 3.2. SKIMMERS TO BE INSTALLED ON OUTLET CONTROL STRUCTURES, AND TURBIDITY CURTAINS ARE TO BE INSTALLED WITHIN THE SEDIMENT BASINS CONCURRENTLY WITH EXCAVATION. SEE SHEET C-504 FOR DETAIL.
  - 3.3. SEDIMENT BASINS ARE TO BE EXCAVATED TO PROPOSED GRADE. SEE SHEET C-502 FOR DETAIL.
4. UPON PLACEMENT OF EXCAVATED MATERIAL.
  - 4.1. SILT FENCE IS TO BE PLACED AROUND STOCKPILE AREAS IN ACCORDANCE WITH THE DETAIL ON SHEET C-503.
  - 4.2. DIVERSIONS ARE TO BE GRADED PRIOR TO MATERIAL PLACEMENT ON LOTS IN ACCORDANCE WITH THE DETAIL ON SHEET C-502. DIVERSION DIKES ARE TO BE GRADED TO PROVIDE POSITIVE DRAINAGE TO THE SEDIMENT BASIN. DIVERSION DEPTHS WILL BE VARIABLE DUE TO FILLING OF SITE. CHECK DAMS ARE TO BE INSTALLED WITHIN EXISTING DITCHES.
5. ONCE ALL E&S MEASURES ARE IN PLACE, ROUGH GRADE IN ACCORDANCE WITH PLANS. EXISTING FARM DITCHES ARE TO BE DEMUCKED AND FILLED IN A MANNER TO MAINTAIN TEMPORARY DRAINAGE AT ALL TIMES. SEED DISTURBED AREAS IMMEDIATELY AFTER GRADING.
6. INSTALL UTILITIES FOR THIS PHASE. ONLY DEMOLISH AND DISTURB AREAS NEEDED TO INSTALL UTILITIES. ONCE THE UTILITIES ARE INSTALLED, THE REMAINING DEMOLITION ITEMS AND DISTURBANCE MAY BEGIN. THE STORM SYSTEM IN THE RIGHT OF WAY MAY BE INSTALLED AT ANY TIME, BUT NOT BEFORE THE EROSION AND SEDIMENT CONTROL MEASURES HAVE BEEN INSTALLED IN THE RIGHT OF WAY.
7. UPON COMPLETION OF ROUGH GRADING AND UTILITY INSTALLATION, PAVING OPERATIONS MAY BEGIN.
8. DRESS AND OVERSEED ALL DISTURBED AREAS AND IMMEDIATELY ESTABLISH PERMANENT VEGETATIVE COVER. MAINTAIN VEGETATIVE COVER THROUGHOUT DURATION OF PROJECT.
9. REPAIR ANY INADVERTENT EROSION AND REMOVE ANY INADVERTENT SEDIMENTATION. CLEANOUT SEDIMENT BASINS TO PROPOSED GRADE AND REMOVE SKIMMERS.
10. REMOVE ALL TEMPORARY EQUIPMENT, CONSTRUCTION MATERIALS AND DEBRIS FROM THE SITE.

C:\Users\jth146\OneDrive\Documents\Projects\New Bridge Creek\CD102.dwg - Friday, April 03, 2020, 4:49pm



**MSA**  
ENGINEERS | SCIENTISTS | SURVEYORS

5032 ROUSE DRIVE, SUITE 200 | VIRGINIA BEACH, VA 23462 | 757.490.9261 | MSAONLINE.COM

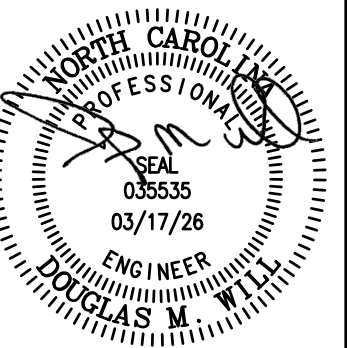

03/17/26  
ENGINEER  
DOUGLAS M. WHITE

DESIGNED	ENL	ENL	DMW	DMW	DATE
DRAWN	CHECKED	APPROVED			03/17/26

DEMOLITION, EROSION & SEDIMENT CONTROL PLAN (PHASE 2)  
OF  
NEW BRIDGE CREEK  
CURRITUCK COUNTY, NORTH CAROLINA  
MOYOCK TOWNSHIP

SHEET  
**CD102**  
5 of 32 Sheets  
SCALE: 1" = 100'  
PROJ. NO.: 24102

FINAL DESIGN  
NOT RELEASED FOR  
CONSTRUCTION

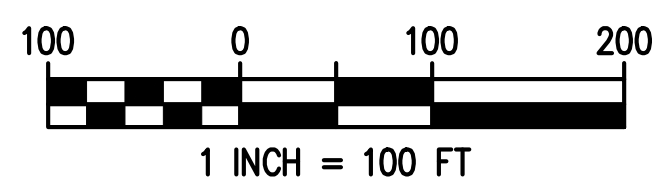

**GENERAL NOTES:**

- NEW BRIDGE CREEK SUBDIVISION IS TO BE CONSTRUCTED IN THREE PHASES. PHASES ARE DENOTED ON THE PLANS.
- ALL MATERIALS EXCAVATED OVER THE COURSE OF CONSTRUCTION SHALL REMAIN ON THE PROJECT SITE. THIS MATERIAL SHALL BE USED FOR FILLING EXISTING DITCHES, CONSTRUCTION OF ROADWAYS AND PREPARING THE RESIDENTIAL LOTS AS ILLUSTRATED ON THE GRADING PLANS. IF NECESSARY, EXCAVATED MATERIALS REMAINING AT THE END OF CONSTRUCTION MAY BE DISPOSED OF OFF-SITE AT AN APPROVED AND PERMITTED BORROW PIT.
- OFF-SITE BORROW, IF NECESSARY, MUST BE OBTAINED FROM AN APPROVED AND PERMITTED BORROW PIT.
- NO GREATER THAN 20 ACRES OF LAND SHALL BE DISTURBED AT ONE TIME. CONSTRUCTION AND STABILIZATION ACTIVITIES SHALL, TO THE MAXIMUM EXTENT PRACTICABLE, BE SCHEDULED ACCORDINGLY.
- THE FOLLOWING PROVIDES AN ESTIMATED MATERIAL BALANCE OF THIS PROJECT:  

APPROXIMATE CUT VOLUME:	75,835 CY±
APPROXIMATE FILL VOLUME:	69,418 CY±
- \*THE VALUES ARE GROSS ESTIMATES AND ARE PROVIDED FOR PERMITTING PURPOSES ONLY. COMPACTION AND SUITABILITY OF SOILS FOR USE IN CONSTRUCTION ARE NOT CONSIDERED AND ADDITIONAL MATERIAL MAY BE NECESSARY. CONTRACTORS SHALL NOT RELY UPON THESE ESTIMATES AND SHOULD DETERMINE THEIR OWN MATERIAL NEEDED FOR CONSTRUCTION.

**SEDIMENT BASIN NOTE:**

DURING CONSTRUCTION, POND #1 & POND #2 SHALL BE UTILIZED AS AN EROSION & SEDIMENT CONTROL SEDIMENT BASIN. AFTER CONSTRUCTION IS COMPLETE AND THE SITE IS PROPERLY STABILIZED THE POND SHALL BE CLEANED AND RESTORED TO ITS DESIGN SPECIFICATIONS AND THE BANKS PERMANENTLY STABILIZED WITHIN 7 DAYS.

**EXISTING DITCH FILL NOTE:**

EXISTING DITCHES NOTED AS BEING FILLED SHALL BE DEMUCKED AND BACKFILLED WITH CLEAN, COMPACTED SELECT MATERIAL. DITCH FILLING SHALL COINCIDE WITH DRAINAGE PATTERNS AND EROSION CONTROL MEASURES AS PROVIDED IN THESE PLANS.

**STOCKPILE AREA NOTE:**

PLACEMENT OF EXCAVATED MATERIAL EITHER DIRECTLY ON THE LOTS OR IN A STOCKPILE WILL BE AT THE DISCRETION OF THE CONTRACTOR. ALL STOCKPILES SHALL INCORPORATE EROSION CONTROL MEASURES IN ACCORDANCE WITH NCDEQ REQUIREMENTS.

**DEMOLITION KEYNOTES:**

- REMOVE TREES, CLEAR & GRUB
- REMOVE HYDRANT. CAP AND ABANDON HYDRANT SERVICE LINE.
- DE-MUCK AND BACKFILL DITCH
- \*COORDINATE WITH DOMINION POWER FOR RELOCATION OF POWER POLE AND UNDERGROUND CONDUIT PLACEMENT
- PROPOSED 74 LF 18" CLASS V RCP (REFER TO SHEET CG101 FOR STORM SCHEDULE AND SHEET CG105 FOR PLAN DETAIL)
- PROPOSED 48 LF 18" CLASS V RCP (REFER TO SHEET CG101 FOR STORM SCHEDULE AND SHEET CG105 FOR PLAN DETAIL)

**EROSION CONTROL LEGEND**

DESCRIPTION	SYMBOL
SILT FENCE (DENOTES LOD)	X (SF)
CONSTRUCTION ENTRANCE	CE
TREE PROTECTION	TP
CHECK DAM	CD

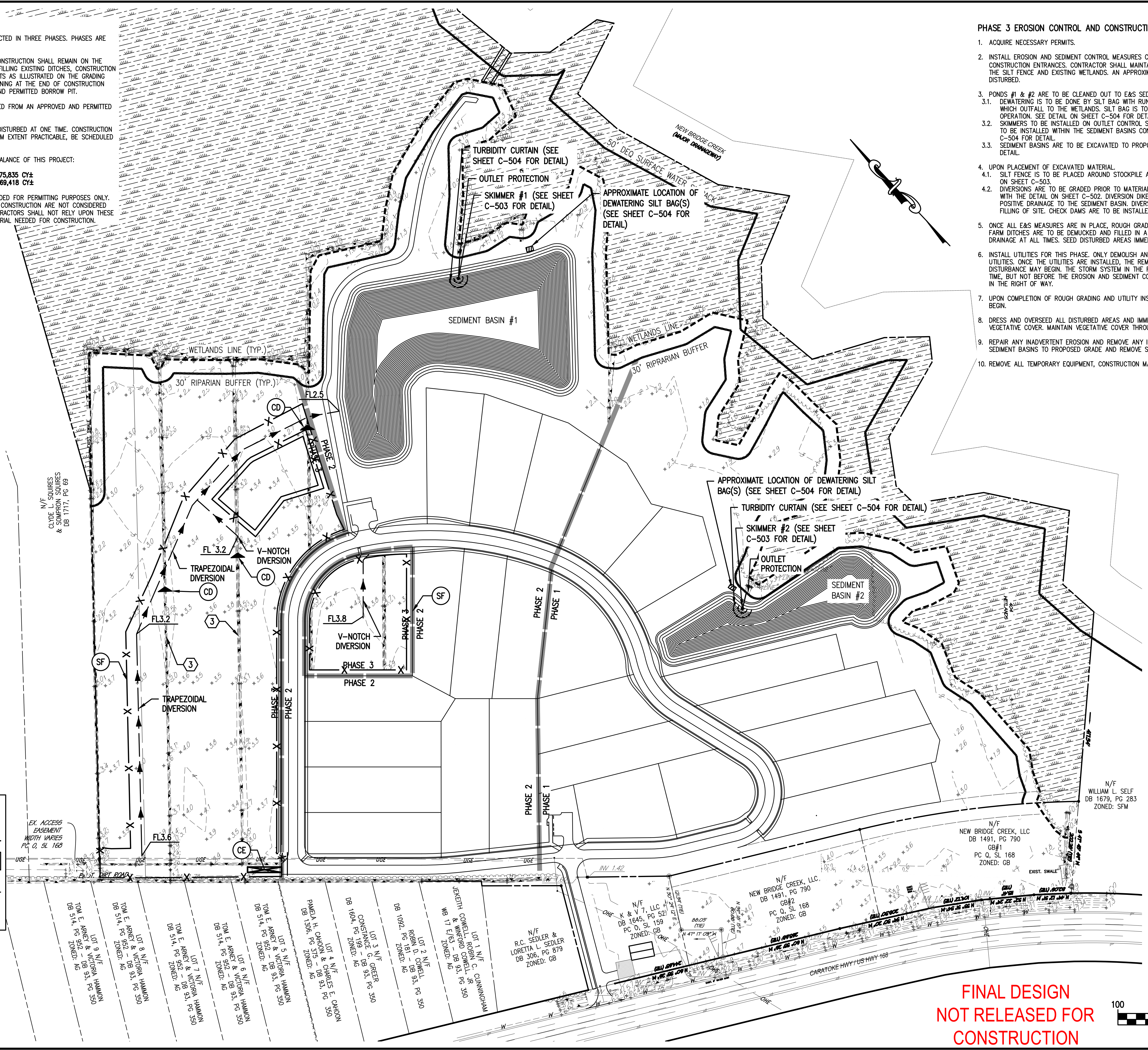

**PHASE 3 EROSION CONTROL AND CONSTRUCTION SEQUENCING:**

- ACQUIRE NECESSARY PERMITS.
- INSTALL EROSION AND SEDIMENT CONTROL MEASURES CONSISTING INITIALLY OF SILT FENCE AND CONSTRUCTION ENTRANCES. CONTRACTOR SHALL MAINTAIN A MINIMUM 3' SEPARATION BETWEEN THE SILT FENCE AND EXISTING WETLANDS. AN APPROXIMATE TOTAL OF 8.33 ACRES ARE TO BE DISTURBED.
- PONDS #1 & #2 ARE TO BE CLEANED OUT TO E&S SEDIMENT BASIN SPECIFICATIONS.
  - DEWATERING IS TO BE DONE BY SILT BAG WITH RUNOFF DIRECTED TO EXISTING DITCHES WHICH OUTFALL TO THE WETLANDS. SILT BAG IS TO BE CONTINUOUSLY MONITORED DURING OPERATION. SEE DETAIL ON SHEET C-504 FOR DETAIL.
  - SKIMMERS TO BE INSTALLED ON OUTLET CONTROL STRUCTURES, AND TURBIDITY CURTAINS ARE TO BE INSTALLED WITHIN THE SEDIMENT BASINS CONCURRENTLY WITH EXCAVATION. SEE SHEET C-504 FOR DETAIL.
  - SEDIMENT BASINS ARE TO BE EXCAVATED TO PROPOSED GRADE. SEE SHEET C-502 FOR DETAIL.
- UPON PLACEMENT OF EXCAVATED MATERIAL.
  - SILT FENCE IS TO BE PLACED AROUND STOCKPILE AREAS IN ACCORDANCE WITH THE DETAIL ON SHEET C-503.
  - DIVERSIONS ARE TO BE GRADED PRIOR TO MATERIAL PLACEMENT ON LOTS IN ACCORDANCE WITH THE DETAIL ON SHEET C-502. DIVERSION DIKES ARE TO BE GRADED TO PROVIDE POSITIVE DRAINAGE TO THE SEDIMENT BASIN. DIVERSION DEPTHS WILL BE VARIABLE DUE TO FILLING OF SITE. CHECK DAMS ARE TO BE INSTALLED WITHIN EXISTING DITCHES.
- ONCE ALL E&S MEASURES ARE IN PLACE, ROUGH GRADE IN ACCORDANCE WITH PLANS. EXISTING FARM DITCHES ARE TO BE DEMUCKED AND FILLED IN A MANNER TO MAINTAIN TEMPORARY DRAINAGE AT ALL TIMES. SEED DISTURBED AREAS IMMEDIATELY AFTER GRADING.
- INSTALL UTILITIES FOR THIS PHASE. ONLY DEMOLISH AND DISTURB AREAS NEEDED TO INSTALL UTILITIES. ONCE THE UTILITIES ARE INSTALLED, THE REMAINING DEMOLITION ITEMS AND DISTURBANCE MAY BEGON. THE STORM SYSTEM IN THE RIGHT OF WAY MAY BE INSTALLED AT ANY TIME, BUT NOT BEFORE THE EROSION AND SEDIMENT CONTROL MEASURES HAVE BEEN INSTALLED IN THE RIGHT OF WAY.
- UPON COMPLETION OF ROUGH GRADING AND UTILITY INSTALLATION, PAVING OPERATIONS MAY BEGIN.
- DRESS AND OVERSEED ALL DISTURBED AREAS AND IMMEDIATELY ESTABLISH PERMANENT VEGETATIVE COVER. MAINTAIN VEGETATIVE COVER THROUGHOUT DURATION OF PROJECT.
- REPAIR ANY INADVERTENT EROSION AND REMOVE ANY INADVERTENT SEDIMENTATION. CLEANOUT SEDIMENT BASINS TO PROPOSED GRADE AND REMOVE SKIMMERS.
- REMOVE ALL TEMPORARY EQUIPMENT, CONSTRUCTION MATERIALS AND DEBRIS FROM THE SITE.



**MSA**  
ENGINEERS | SCIENTISTS | SURVEYORS

5032 ROUSE DRIVE, SUITE 200 | VIRGINIA BEACH, VA 23462 | 757.490.9264 | MSAONLINE.COM

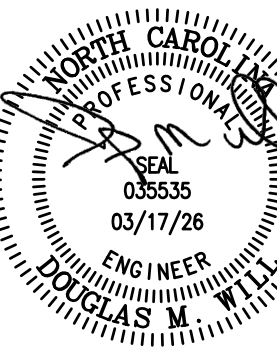

DOUGLAS M. LITTLE  
ENGINEER  
03/17/26

DESIGNED	ENL	ENL	DMW	DMW	DATE
DRAWN	CHECKED	APPROVED			03/17/26

DEMOLITION, EROSION & SEDIMENT CONTROL PLAN (PHASE 3)

OF

**NEW BRIDGE CREEK**

CURRITUCK COUNTY, NORTH CAROLINA

MOTOCK TOWNSHIP

SHEET  
**CD103**  
6 of 32 Sheets  
SCALE: 1" = 100'  
PROJ. NO.: 24102

FINAL DESIGN  
NOT RELEASED FOR  
CONSTRUCTION

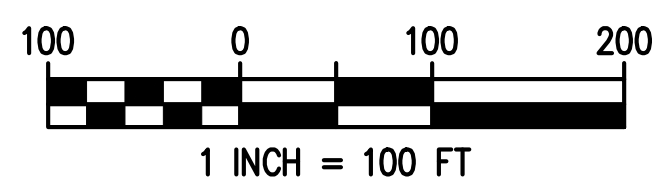

C:\Users\jth146\OneDrive\Local\Temp\jth146\jth146\_24102\_24102\_24102.dwg - Friday, April 03, 2026, 4:49pm

I:\Projects\24102 New Bridge Creek Subdivision\Engineering\Drawings & Exhibits\DWG\24102 Subdivision Plan.dwg [CG101] - Friday, April 03, 2026, 4:58pm

PROPOSED STORM SEWER STRUCTURE TABLE		
ID	TYPE	RIM & INVERT
OF1	PIPE END	RIM=??? INV(ST-24)=-0.50 (24" HDPE)
OF2	PIPE END	RIM=??? INV(ST-13)=0.40 (24" HDPE)
ST-1	PIPE END	RIM=??? INV(ST-2)=2.75 (18" HP)
ST-2	PIPE END	RIM=??? INV(ST-1)=2.48 (18" HP)
ST-3	PIPE END	RIM=??? INV(ST-4)=4.32 (15" CLASS V RCP)
ST-4	PIPE END	RIM=??? INV(ST-3)=4.06 (15" CLASS V RCP)
ST-5	PIPE END	RIM=??? INV(ST-6)=3.76 (15" CLASS V RCP)
ST-6	PIPE END	RIM=??? INV(ST-5)=3.70 (15" CLASS V RCP)
ST-7	FES	RIM=??? INV(ST-8)=3.20 (24" CLASS V RCP)
ST-8	FES	RIM=??? INV(ST-7)=2.46 (24" CLASS V RCP)
ST-9	HEADWALL	SEE SHEET C-502 FOR DETAIL INV(ST-10)=2.46 (27" CLASS V RCP)
ST-10	HEADWALL	SEE SHEET C-502 FOR DETAIL INV(ST-9)=2.34 (27" CLASS V RCP)
ST-11	FES	RIM=??? INV(ST-12)=2.34 (30" RCP)
ST-12	PIPE END	RIM=??? INV(ST-11)=-2.00 (30" RCP)
ST-13	OCS-2	SEE SHEET C-502 FOR DETAIL INV(OF2)=0.60 (24" HDPE)
ST-14	PIPE END	RIM=??? INV(ST-15)=3.10 (24" CLASS V RCP)
ST-15	FES	RIM=??? INV(ST-14)=2.62 (24" CLASS V RCP)
ST-16	HEADWALL	SEE SHEET C-502 FOR DETAIL INV(ST-17)=2.62 (30" CLASS V RCP)
ST-17	HEADWALL	SEE SHEET C-502 FOR DETAIL INV(ST-16)=2.39 (30" CLASS V RCP)
ST-18	FES	RIM=??? INV(ST-19)=2.39 (30" CLASS V RCP)
ST-19	PIPE END	RIM=??? INV(ST-18)=2.31 (30" CLASS V RCP)
ST-20	PIPE END	RIM=??? INV(ST-21)=3.30 (18" CLASS V RCP)
ST-21	PIPE END	RIM=??? INV(ST-20)=2.94 (18" CLASS V RCP)
ST-22	PIPE END	RIM=??? INV(ST-23)=2.62 (24" CLASS V RCP)
ST-23	PIPE END	RIM=??? INV(ST-22)=2.50 (24" CLASS V RCP)
ST-24	OCS-1	SEE SHEET C-502 FOR DETAIL INV(OF1)=-0.30 (24" HDPE)
ST-25	PIPE END	RIM=??? INV(ST-26)=4.12 (15" CLASS V RCP)
ST-26	PIPE END	RIM=??? INV(ST-25)=4.06 (15" CLASS V RCP)
ST-27	PIPE END	RIM=??? INV(ST-28)=3.90 (15" CLASS V RCP)
ST-28	PIPE END	RIM=??? INV(ST-27)=3.71 (15" CLASS V RCP)
ST-29	PIPE END	RIM=??? INV(ST-30)=3.33 (18" CLASS V RCP)
ST-30	PIPE END	RIM=??? INV(ST-29)=3.28 (18" CLASS V RCP)
ST-31	PIPE END	RIM=??? INV(ST-32)=3.50 (18" CLASS V RCP)
ST-32	PIPE END	RIM=??? INV(ST-31)=3.30 (18" CLASS V RCP)



PROPOSED STORM SEWER PIPE TABLE	
STRUCTURE TO STRUCTURE	LENGTH - SIZE/TYPE @ SLOPE
ST-1 TO ST-2	74 LF - 18" HP @ 0.36%
ST-3 TO ST-4	88 LF - 15" CLASS V RCP @ 0.30%
ST-5 TO ST-6	18 LF - 15" CLASS V RCP @ 0.33%
ST-7 TO ST-8	14 LF - 24" CLASS V RCP @ 5.34%*
ST-9 TO ST-10	30 LF - 27" CLASS V RCP @ 0.40%
ST-11 TO ST-12	23 LF - 30" RCP @ 18.64%*
ST-13 TO OF2	35 LF - 24" HDPE @ 0.57%
ST-14 TO ST-15	12 LF - 24" CLASS V RCP @ 4.08%*
ST-16 TO ST-17	41 LF - 30" CLASS V RCP @ 0.57%

PROPOSED STORM SEWER PIPE TABLE	
STRUCTURE TO STRUCTURE	LENGTH - SIZE/TYPE @ SLOPE
ST-18 TO ST-19	11 LF - 30" CLASS V RCP @ 0.75%*
ST-20 TO ST-21	72 LF - 18" CLASS V RCP @ 0.50%
ST-22 TO ST-23	41 LF - 24" CLASS V RCP @ 0.29%
ST-24 TO OF1	45 LF - 24" HDPE @ 0.44%
ST-25 TO ST-26	18 LF - 15" CLASS V RCP @ 0.34%
ST-27 TO ST-28	29 LF - 15" CLASS V RCP @ 0.67%
ST-29 TO ST-30	17 LF - 18" CLASS V RCP @ 0.29%
ST-31 TO ST-32	48 LF - 18" CLASS V RCP @ 0.42%

\* PIPE SLOPE DOES NOT ACCOUNT FOR FES LENGTH. INVERTS SPECIFIED DENOTE STRUCTURE FES TO FES. SEE SHEET C-502 FOR DETAIL.

MINIMUM FINISHED FLOOR ELEVATIONS ARE EQUAL TO BUILDING PAD ELEVATIONS (BPE) SHOWN HEREON

**FINAL DESIGN  
NOT RELEASED FOR  
CONSTRUCTION**

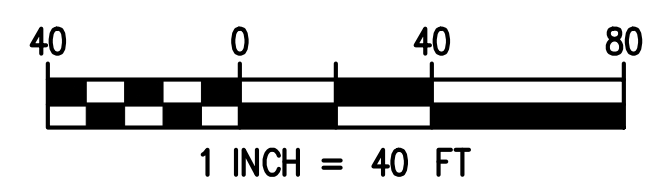



**MSA**  
ENGINEERS | SCIENTISTS | SURVEYORS  
5032 ROUSE DRIVE, SUITE 200 | VIRGINIA BEACH, VA 23462 | 757.490.9264 | MSAONLINE.COM

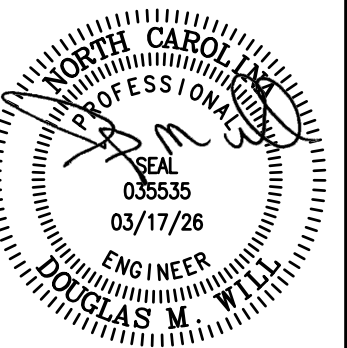

PROFESSIONAL ENGINEER  
DOUGLAS M. WHITE  
035335  
03/17/26

DESIGNED	ENL	JTP	DMW	DMW	DATE
DRAWN					03/17/26
CHECKED					
APPROVED					

MASTER GRADING & DRAINAGE PLAN  
OF  
**NEW BRIDGE CREEK**

CURRITUCK COUNTY, NORTH CAROLINA  
MOYOCK TOWNSHIP

SHEET  
**CG101**  
7 of 32 Sheets  
SCALE: 1" = 40'  
PROJ. NO.: 24102

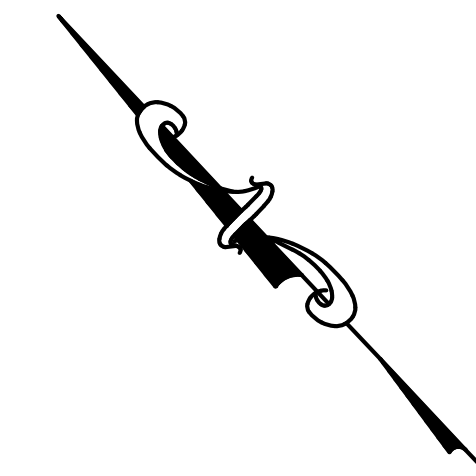

MATCH LINE SEE SHEET CG103

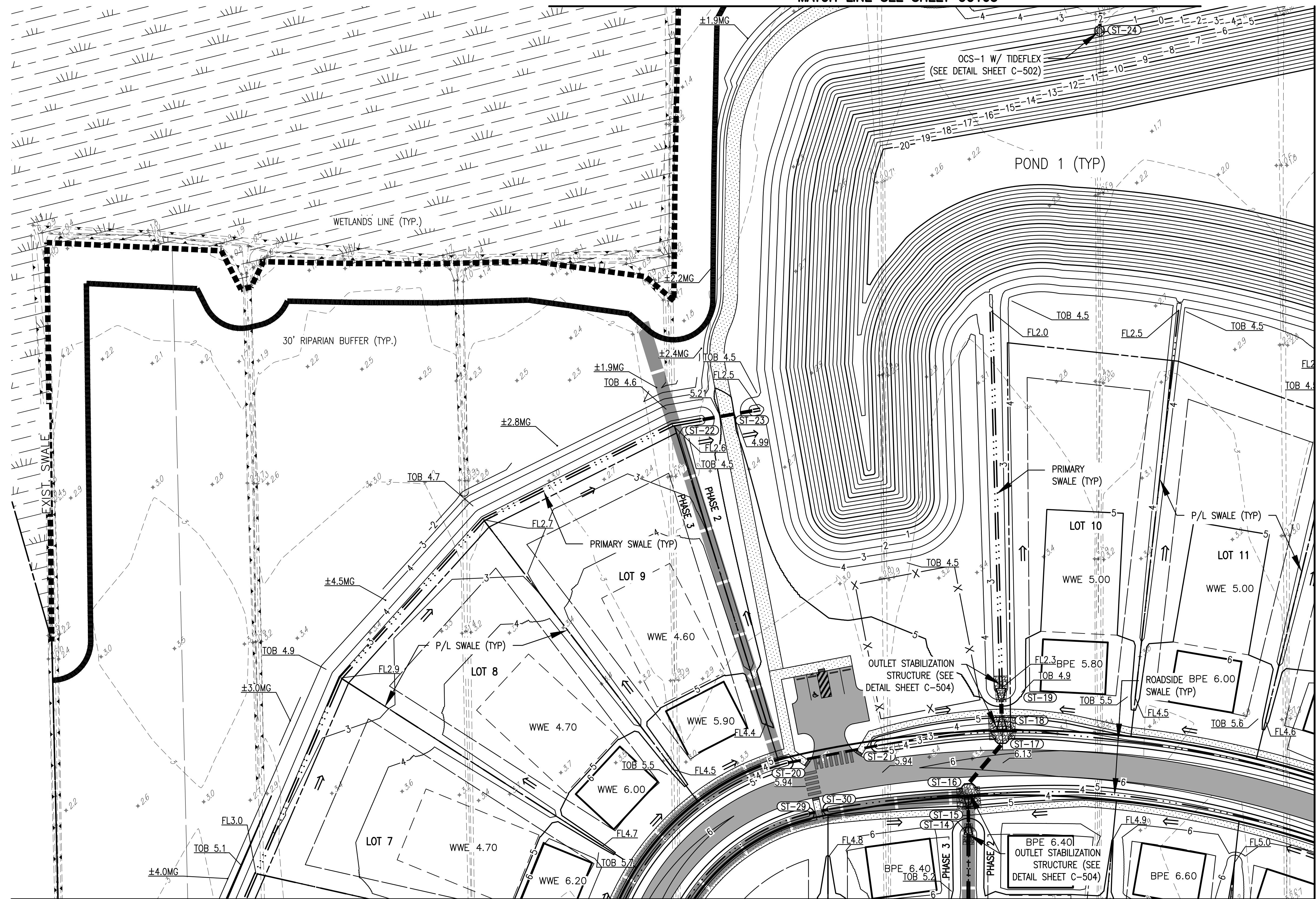

MATCH LINE SEE SHEET CG101

MATCH LINE SEE SHEET CG104

I:\Projects\24102 New Bridge Creek Subdivision\Engineering\Drawings & Exhibits\DWG\24102 Subdivision Plan.dwg [CG102] - Friday, April 03, 2026, 4:50pm

MINIMUM FINISHED FLOOR ELEVATIONS  
ARE EQUAL TO BUILDING PAD  
ELEVATIONS (BPE) SHOWN HEREON

**FINAL DESIGN  
NOT RELEASED FOR  
CONSTRUCTION**

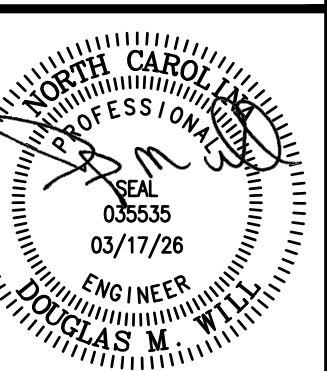
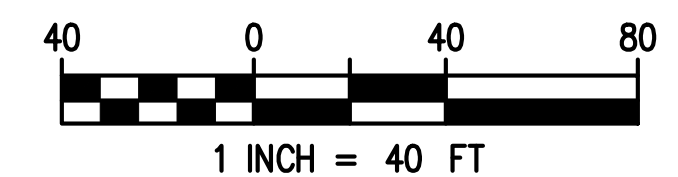

DESIGNED	ENL
DRAWN	JTP
CHECKED	DMW
APPROVED	DMW
DATE	03/17/26

REVISION	DATE	BY	DESCRIPTION

MASTER GRADING & DRAINAGE PLAN  
OF  
**NEW BRIDGE CREEK**  
CURRITUCK COUNTY, NORTH CAROLINA  
MOYOCK TOWNSHIP

SHEET  
**CG102**  
8 of 32 Sheets  
SCALE: 1" = 40'  
PROJ. NO.: 24102

5032 ROUSE DRIVE, SUITE 200 | VIRGINIA BEACH, VA 23462 | 757.490.9264 | MSAONLINE.COM



I:\Projects\24102 New Bridge Creek Subdivision\Engineering\Drawings & Exhibits\DWG\24102 Subdivision Plan.dwg [CG104] - Friday, April 03, 2026, 4:50pm



MATCH LINE SEE SHEET CG103

MATCH LINE SEE SHEET CG102

MATCH LINE SEE SHEET CG105

FINAL DESIGN  
NOT RELEASED FOR  
CONSTRUCTION

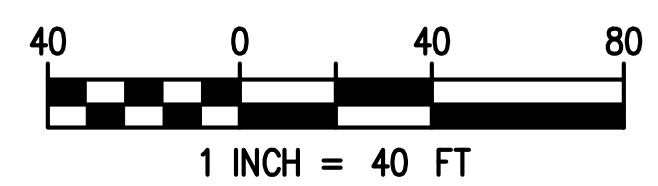

MINIMUM FINISHED FLOOR ELEVATIONS  
ARE EQUAL TO BUILDING PAD  
ELEVATIONS (BPE) SHOWN HEREON

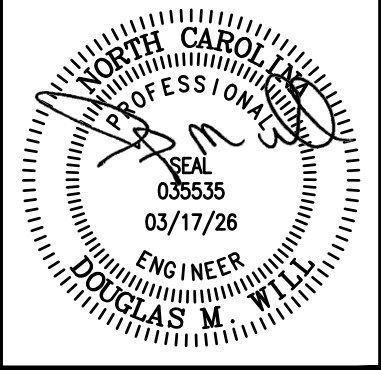

DESIGNED	ENL	JTP	DMW	DMW	DATE
DRAWN					03/17/26
CHECKED					
APPROVED					

REVISION	DATE	BY	DESCRIPTION

MATCH LINE SEE SHEET CG104

MATCH LINE SEE THIS SHEET

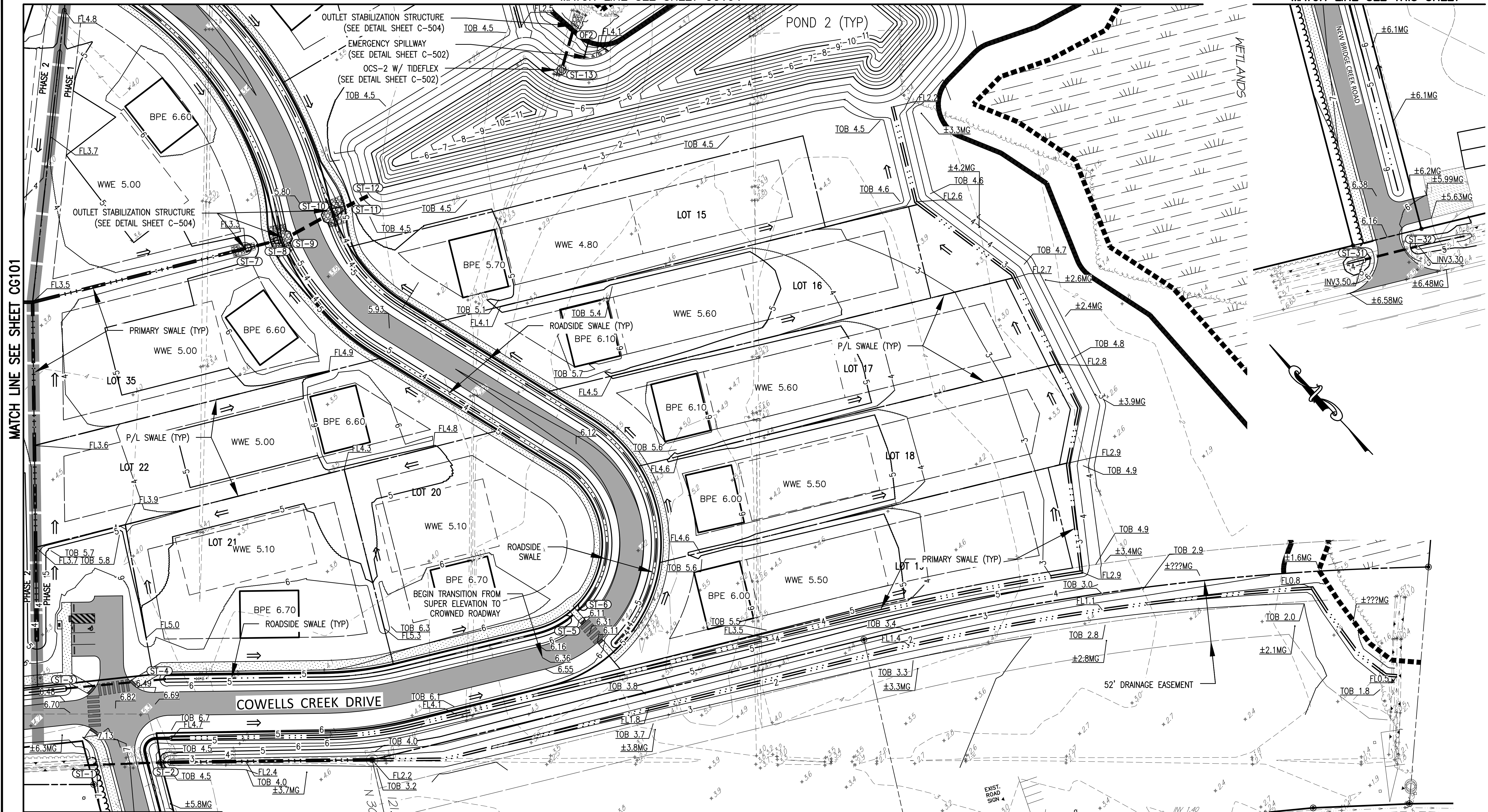

MATCH LINE SEE SHEET CG101

1:\Projects\24102 New Bridge Creek Subdivision\Engineering\Drawings & Exhibits\DWG\24102 Subdivision Plan.dwg [CG105] - Friday, April 03, 2026, 4:50pm

MATCH LINE SEE THIS SHEET

MINIMUM FINISHED FLOOR ELEVATIONS ARE EQUAL TO BUILDING PAD ELEVATIONS (BPE) SHOWN HEREON

FINAL DESIGN NOT RELEASED FOR CONSTRUCTION

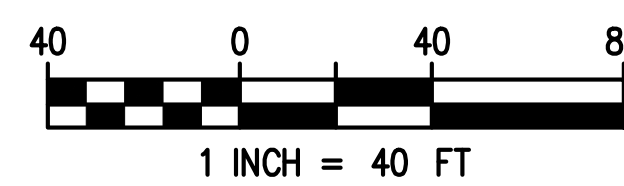



**MSA**  
ENGINEERS | SCIENTISTS | SURVEYORS

5032 ROUSE DRIVE, SUITE 200 | VIRGINIA BEACH, VA 23462 | 757.490.9264 | MSAONLINE.COM

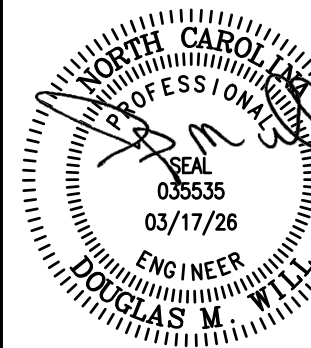

DESIGNED	JTP	DMW	DMW	DATE	03/17/26
DRAWN	CHECKED	APPROVED			

MASTER GRADING & DRAINAGE PLAN  
OF  
**NEW BRIDGE CREEK**

CURRITUCK COUNTY, NORTH CAROLINA

MOYOCK TOWNSHIP

SHEET  
**CG105**  
11 of 32 Sheets

SCALE: 1" = 40'

PROJ. NO.: 24102

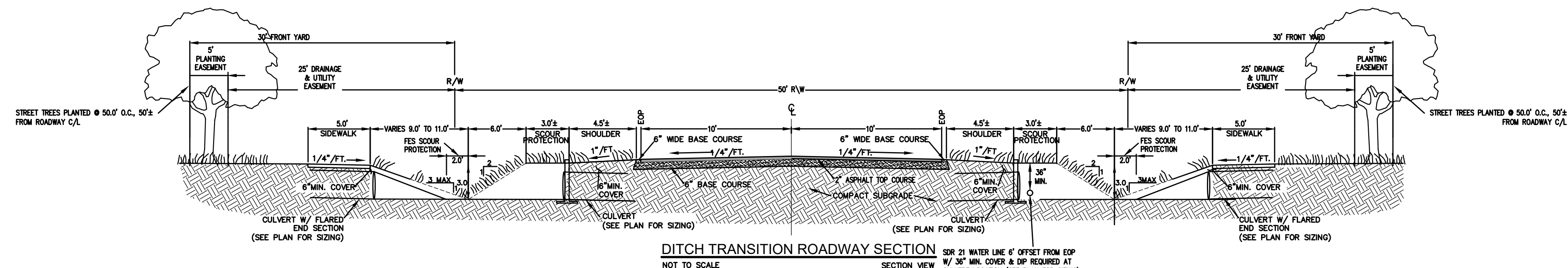
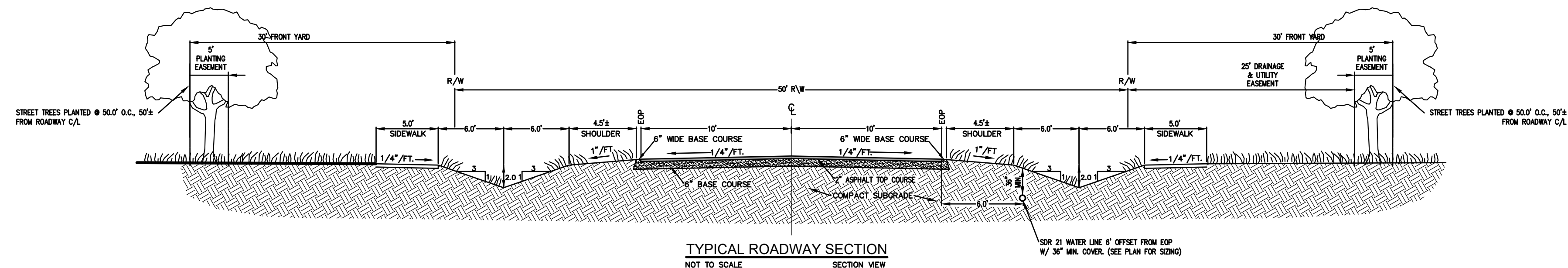

TRANSITION LOCATIONS TABLE with columns for Side of Road, Start Transition Location, Max Depth, and End Transition Location.

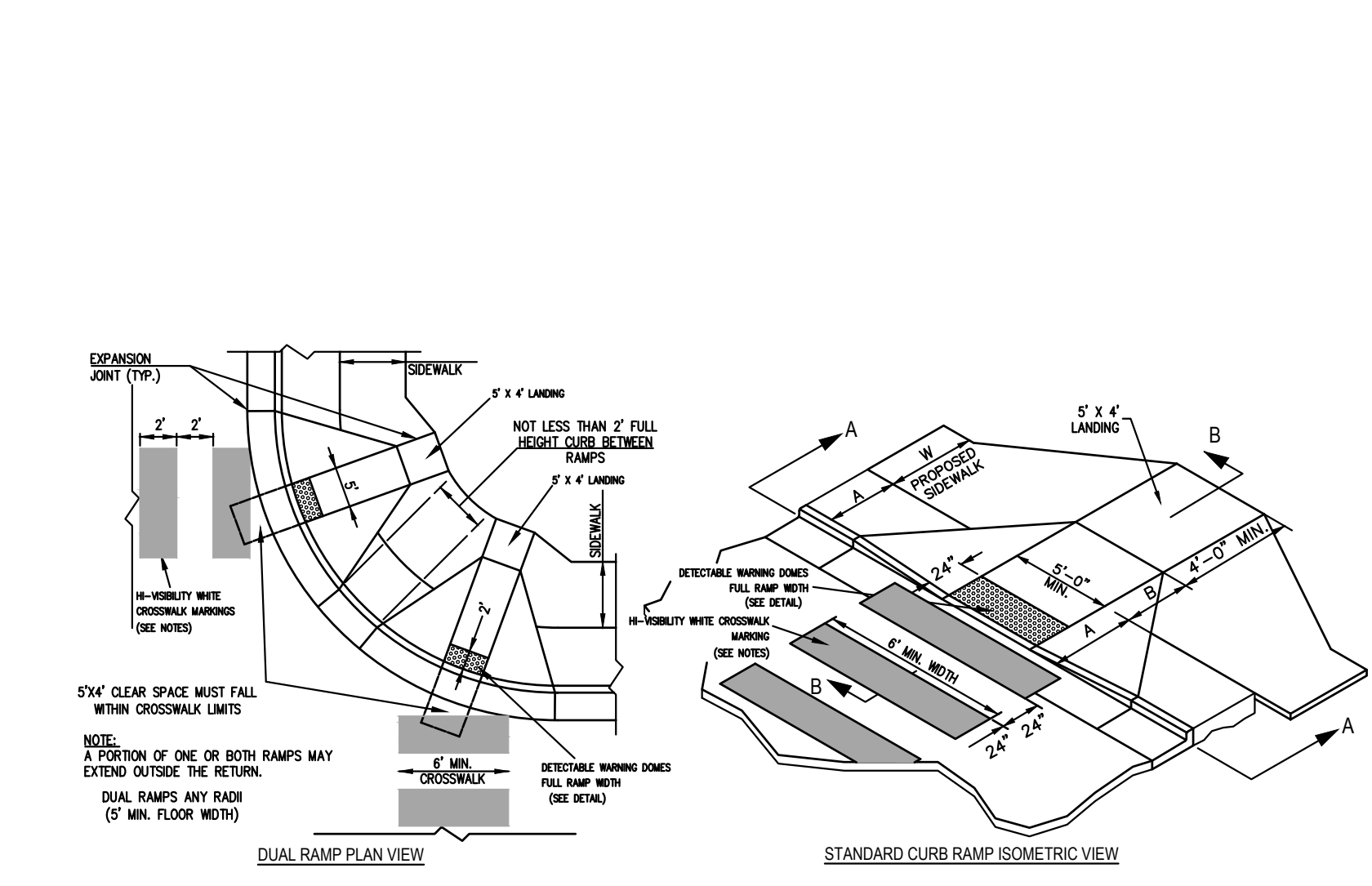
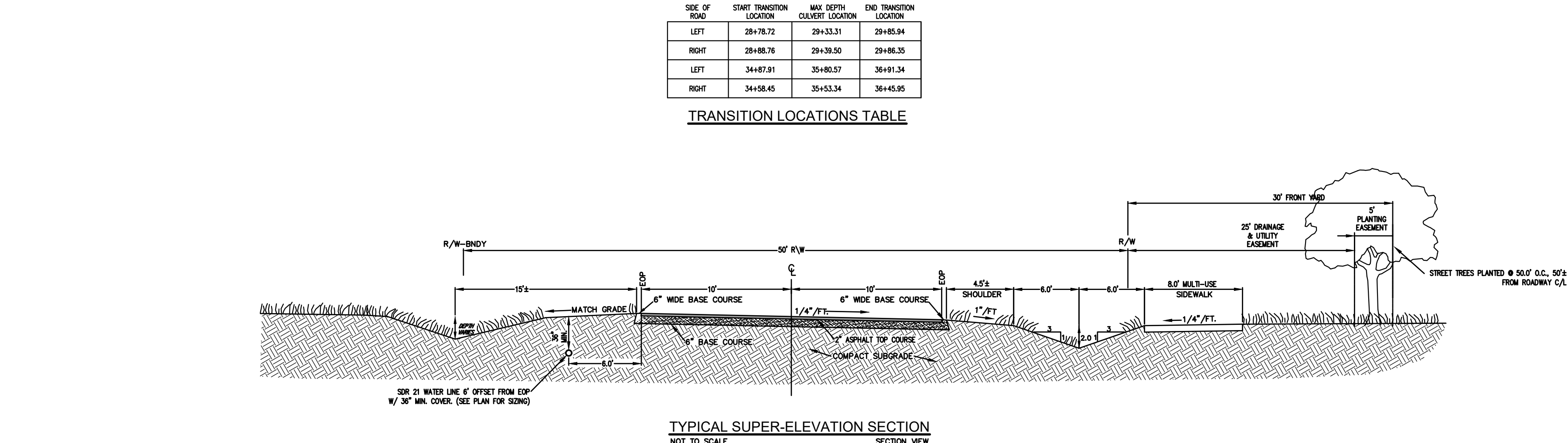

ACCESSIBLE RAMP GENERAL NOTES: (NCDOT STD. DETAIL 848.05)
1. CONSTRUCT THE RAMP SURFACE TO BE STABLE, FIRM AND SLIP RESISTANT...
2. LOCATE CURB RAMPS AND PLACE PEDESTRIAN CROSSWALK MARKINGS AS SHOWN ON THE PROJECT DRAWINGS...

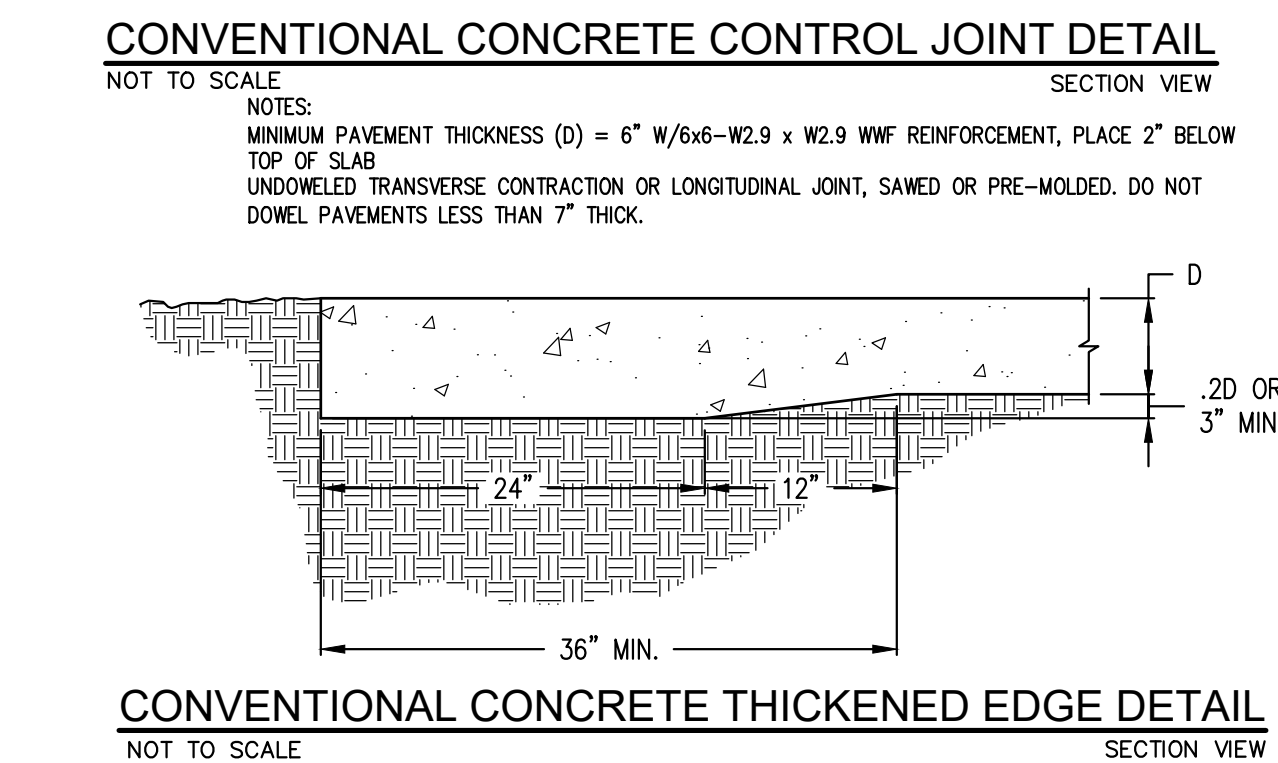
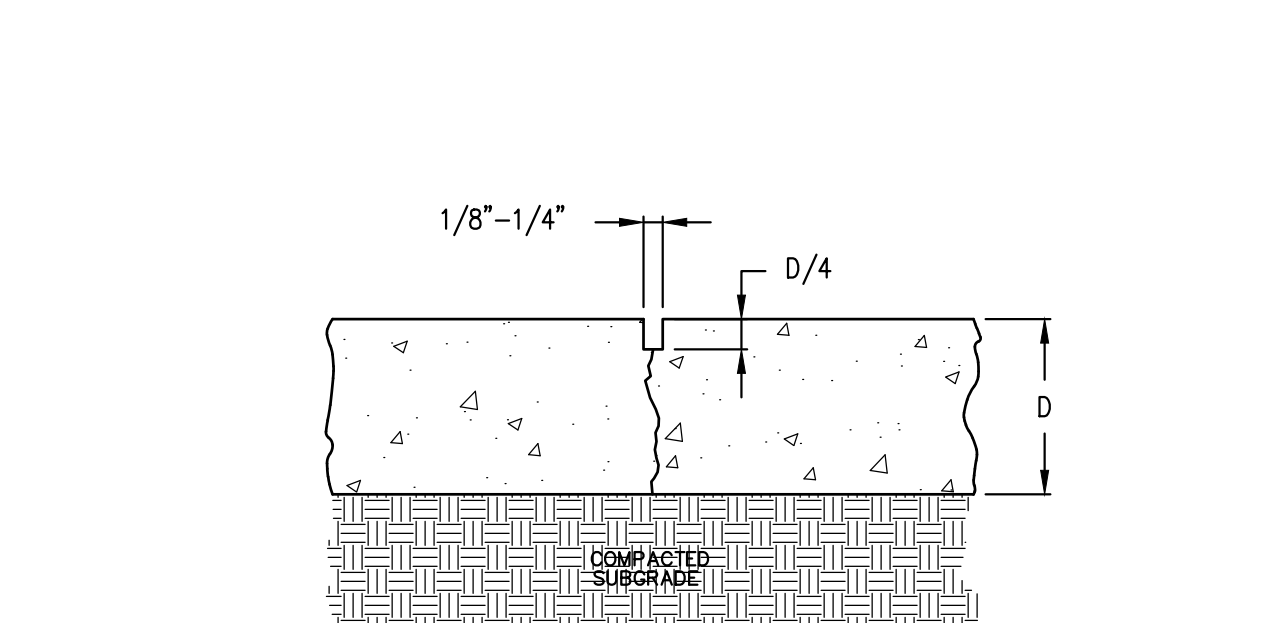

CONVENTIONAL CONCRETE SPECIFICATIONS:
1. USE A/C CERTIFIED FLATWORK FINISHER
2. USE ACI 330R-01 GUIDE FOR DESIGN AND CONSTRUCTION OF CONCRETE PARKING LOTS
3. USE ACI 330.1-94 STANDARD SPECIFICATION FOR PLAIN CONCRETE PARKING LOTS

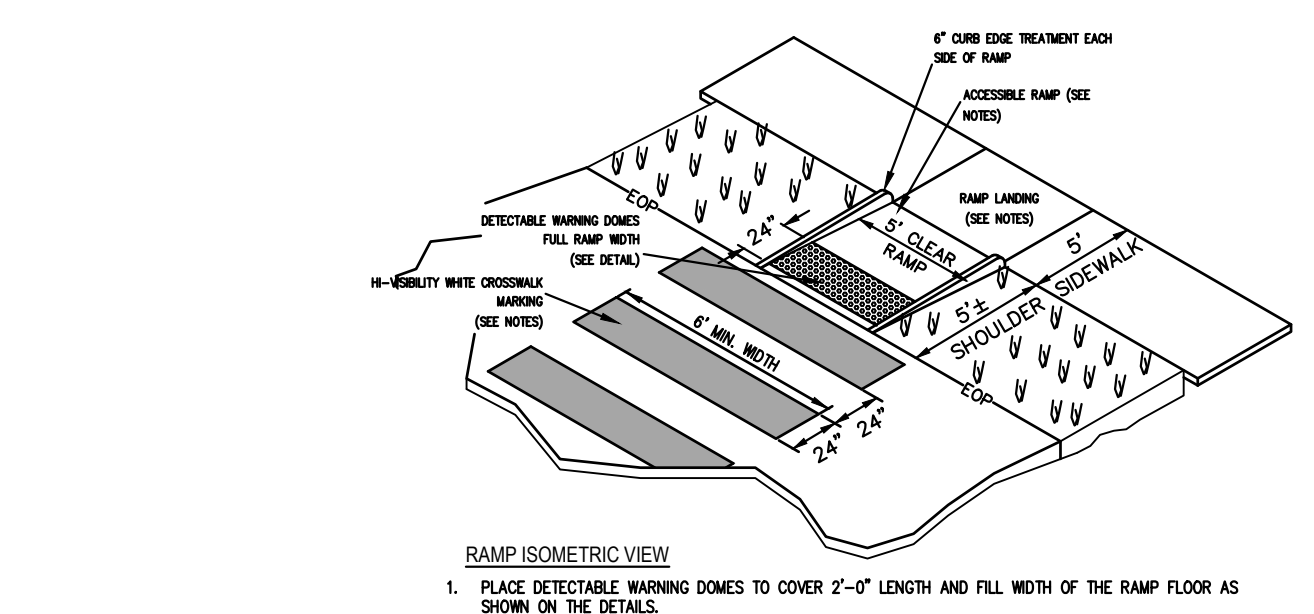

TYP. ACCESSIBLE RAMP DETAIL NOT TO SCALE. ALT. TO NCDOT STD 848.05

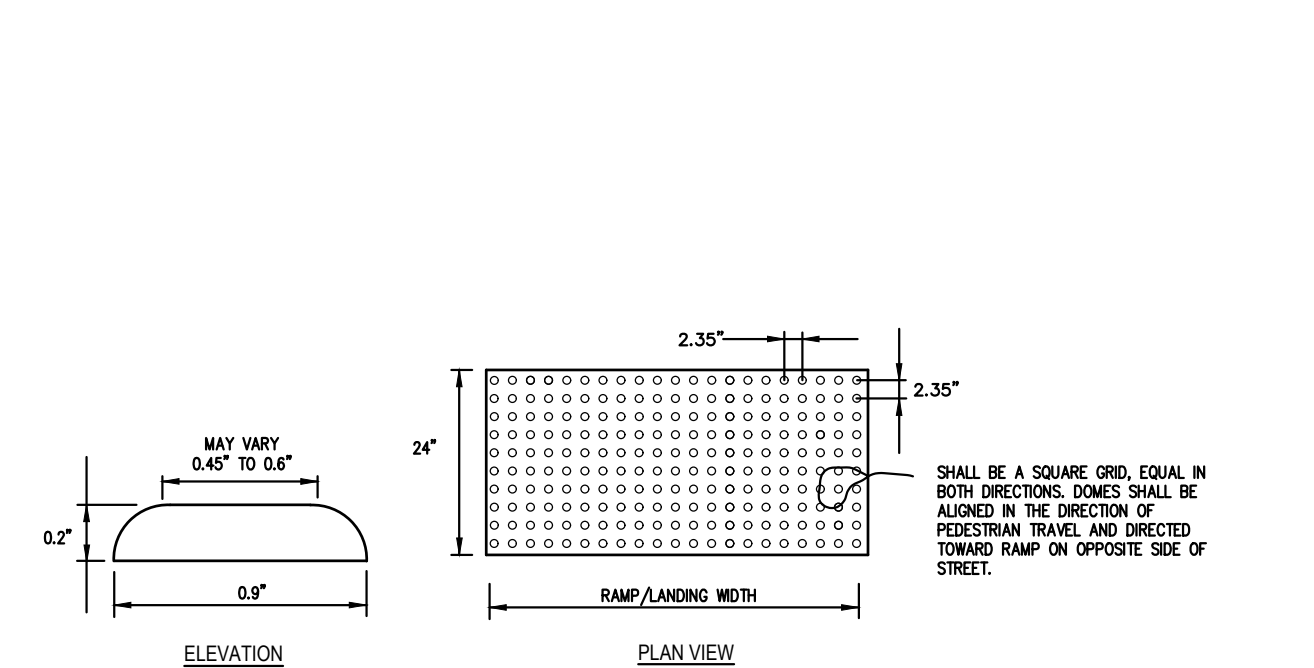

DETECTABLE WARNING GENERAL NOTES:
1. DETECTABLE WARNING SHALL CONSIST OF RAISED TRUNCATED DOMES MANUFACTURED BY 'COTE-L INDUSTRIES, INC.' CALLED 'SAFTI-TRAX'...

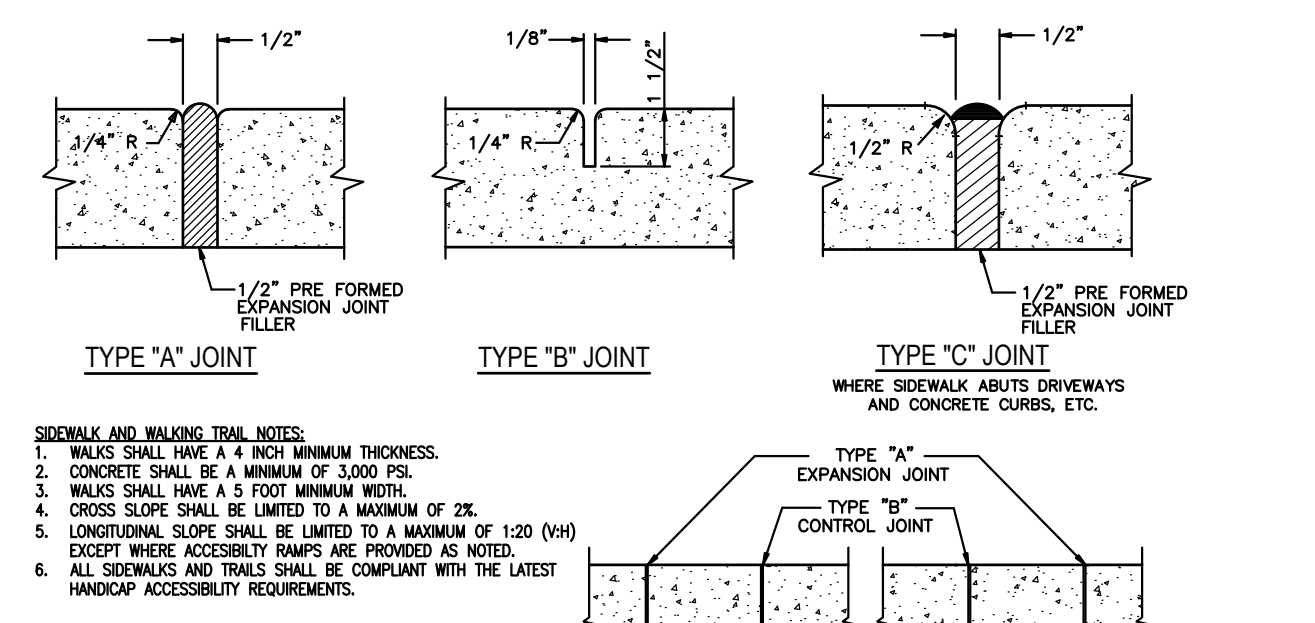
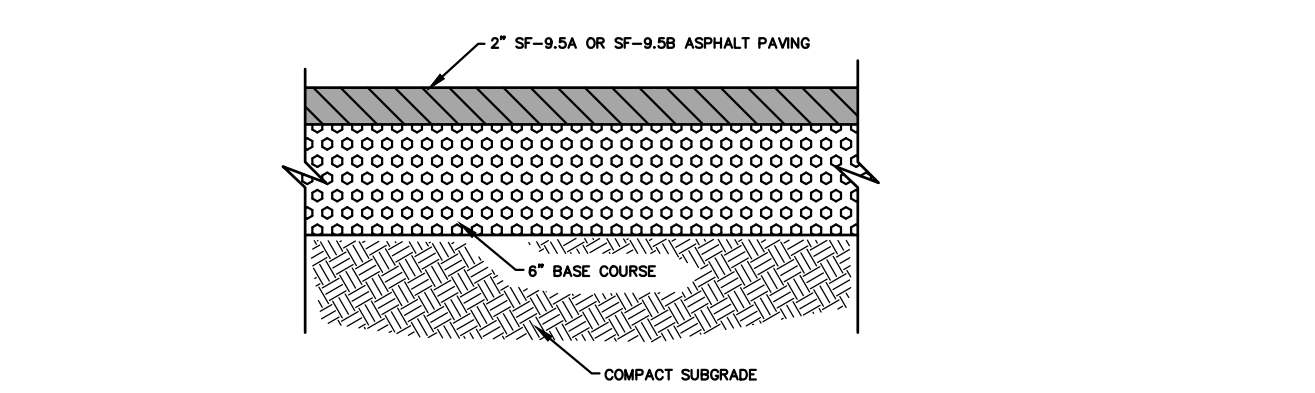
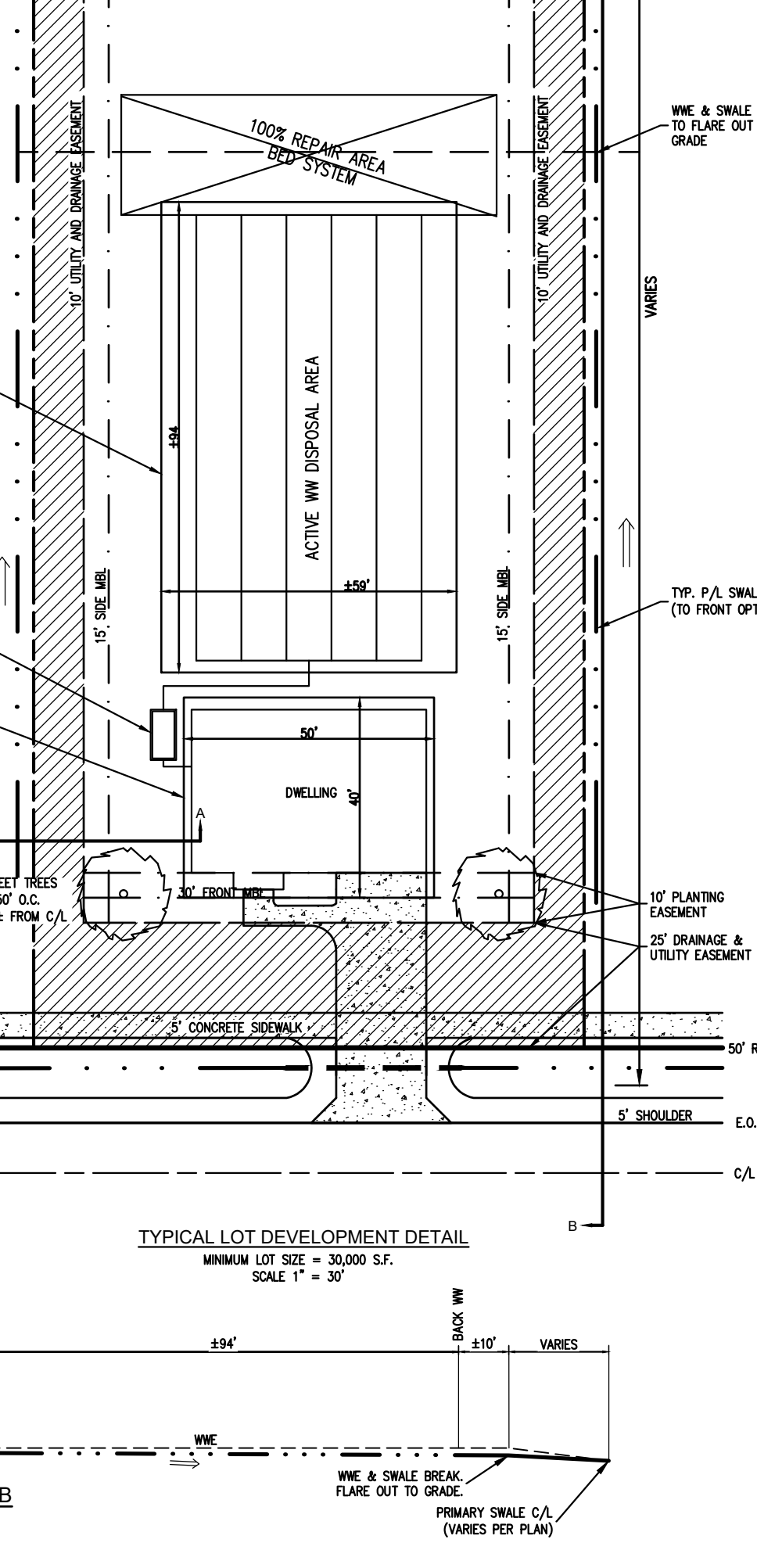
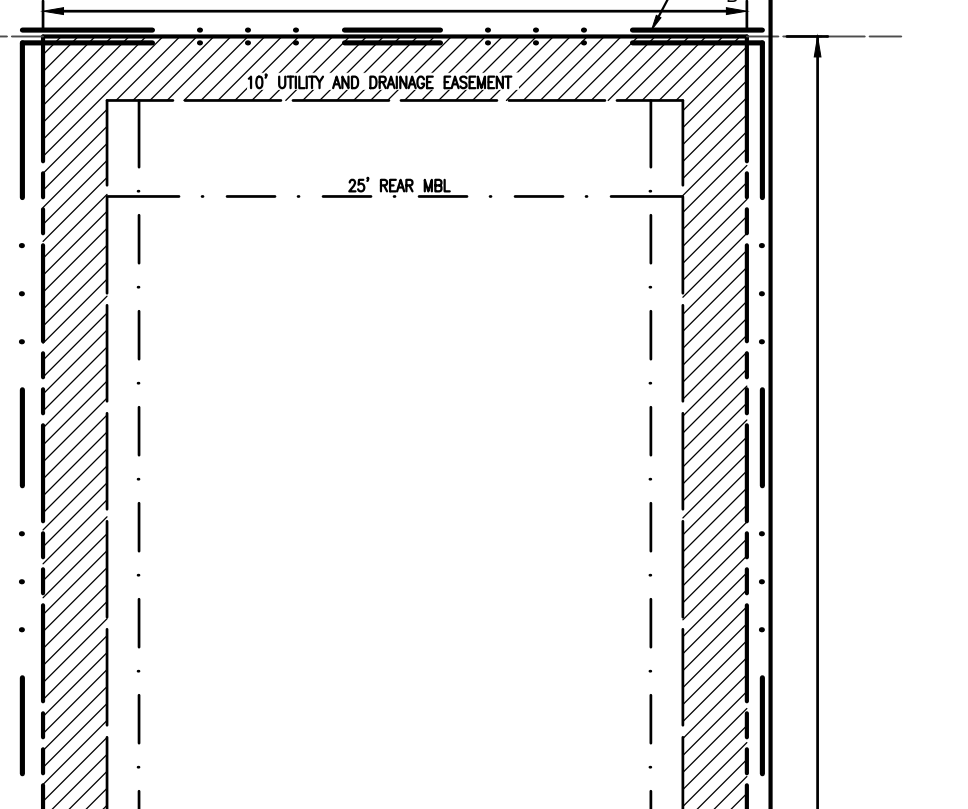
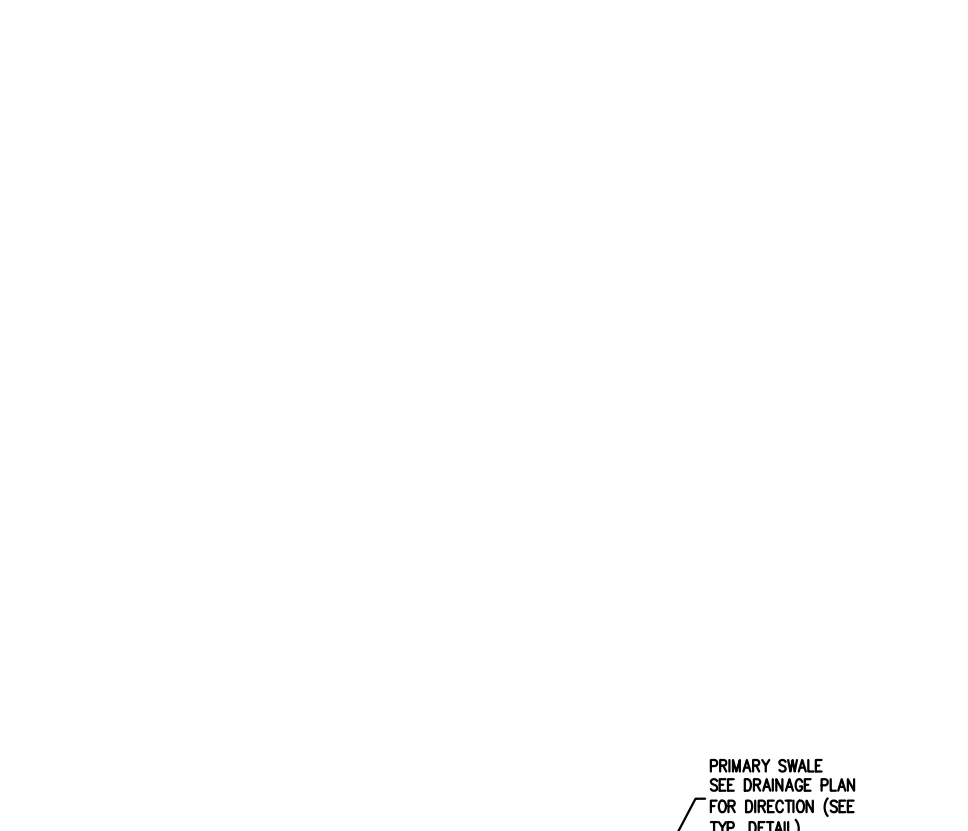
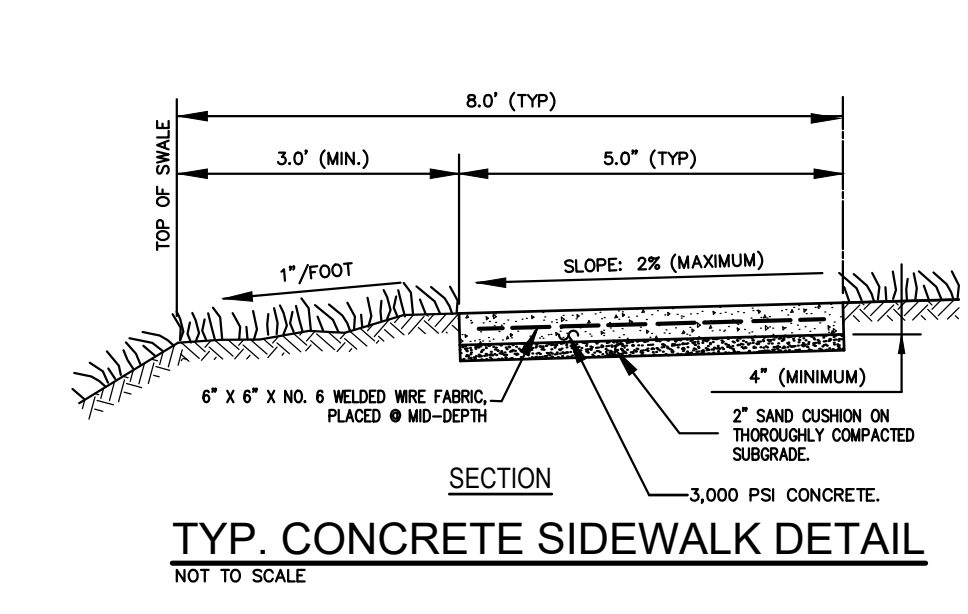

TABLE OF SIDEWALK JOINTS with columns for Type and Location.



CONVENTIONAL CONCRETE THICKENED EDGE DETAIL NOT TO SCALE. SECTION VIEW showing details of a thickened edge for a concrete slab.



MSA ENGINEERS | SCIENTISTS | SURVEYORS
PROF. ENGINEER
NEW BRIDGE CREEK
A 35 LOT RESIDENTIAL SUBDIVISION
CURRITUCK COUNTY NORTH CAROLINA
MOYOCK TOWNSHIP
SHEET C-501
27 of 32 Sheets
SCALE: AS SHOWN
PROJ. NO.: 24102

FINAL DESIGN
NOT RELEASED FOR
CONSTRUCTION



**GENERAL PROJECT NOTES:**

- PROJECT NAME: NEW BRIDGE CREEK MOYOCK, CURRITUCK COUNTY, NORTH CAROLINA
- APPLICANT: NEW BRIDGE CREEK, LLC  
C/O LERRY OLD, AGENT  
101 OAK STREET  
MOYOCK, NC 27958
- PROJECT DESCRIPTION: 35 LOT RESIDENTIAL SUBDIVISION
- NEAREST RECEIVING STREAM: NEW BRIDGE CREEK
- STREAM CLASSIFICATION: C, Sw., PASQUOTANK RIVER BASIN
- PROJECT AREA TABULATION:
 

TOTAL PROPERTY AREA:	±104.09 AC.
TOTAL PROPOSED DISTURBED AREA:	±40.92 AC.
- AREA CALCULATION NOTE:  
All areas have been calculated utilizing properties within the Autocad software.
- MATERIAL BALANCE NOTE:  
All excavated material occurring during the course of construction shall remain on-site for roadway construction and lot grading. See SCHEDULE OF LAND DISTURBING ACTIVITIES provided on Sheet 5 of this set for an estimated cut/fill material balance for the project.
- WETLAND NOTE:  
404 Jurisdictional wetlands have been identified on the property. Disturbance will not occur within the jurisdictional wetlands.
- STABILIZATION NOTE:  
The angle of graded slopes and fills shall be no greater than the angle that can be retained by vegetative cover or other adequate erosion control devices or structures. In any event, all disturbed areas left exposed will, WITHIN 14 CALENDAR DAYS OF COMPLETION of any phase of grading, be planted or otherwise provided with temporary or permanent ground cover, devices, or structures sufficient to restrain erosion. Additionally, certain critical areas as identified on the plan, such as, but not limited to, perimeter dikes, swales, slopes steeper than 3:1, and areas located within High Quality Water Zones, must be temporarily or permanently stabilized WITHIN 7 CALENDAR DAYS OF COMPLETION of any phase of grading in these areas. A permanent ground cover for all disturbed areas must be provided WITHIN 15 WORKING DAYS OR 90 CALENDAR DAYS (whichever is shorter) following completion of construction or development.

**SEDIMENTATION AND EROSION CONTROL NOTES:**

- A. NARRATIVE AND SITE DATA**
- THE PROPOSED PROJECT, NEW BRIDGE CREEK SUBDIVISION, IS LOCATED OFF CARATOKE HIGHWAY IN MOYOCK TOWNSHIP, CURRITUCK COUNTY, NORTH CAROLINA. THE PROJECT WILL CREATE 35 SINGLE-FAMILY HOME LOTS OVER THREE PHASES OF DEVELOPMENT.
- THE PROJECT AREA IS BOUND TO THE SOUTH AND WEST BY THE EXISTING RESIDENTIAL DEVELOPMENT, AND TO THE NORTH AND EAST BY WETLANDS. THIS PROJECT IS PLANNED TO BE DESIGNED AND CONSTRUCTED AS A LOW-DENSITY RESIDENTIAL COMMUNITY IN NORTH CAROLINA, FOCUSING ON CREATING A SUSTAINABLE AND SPACIOUS ENVIRONMENT THAT ALIGNS WITH THE REGION'S DEVELOPMENT GOALS.
- THE CURRENT LAND COVER CONSISTS OF LARGELY UNDEVELOPED FARMLAND AND A PORTION OF PRIVATE ACCESS ROAD. THE AVERAGE SITE ELEVATION IS APPROXIMATELY 4 FEET (NAVD 80) AND RANGES FROM APPROXIMATELY 0.93 TO 7.48 FEET (NAVD 80). EXISTING RUNOFF IS DIRECTED TO VARIOUS ONSITE FARM DITCHES OR TO THE SOUTHERN SITE BOUNDARY. FARM DITCHES ULTIMATELY DISCHARGE TO NEW BRIDGE CREEK THEN TO TULL BAY. UNDERLYING SITE SOILS ARE CLASSIFIED AS ROANOKES SILT LOAM, AND CONSIST OF SILT LOAM, FAT CLAY, FINE SANDY LOAM, AND CLEAN SAND HAS BEEN OBSERVED DURING SOIL BORING OPERATIONS.

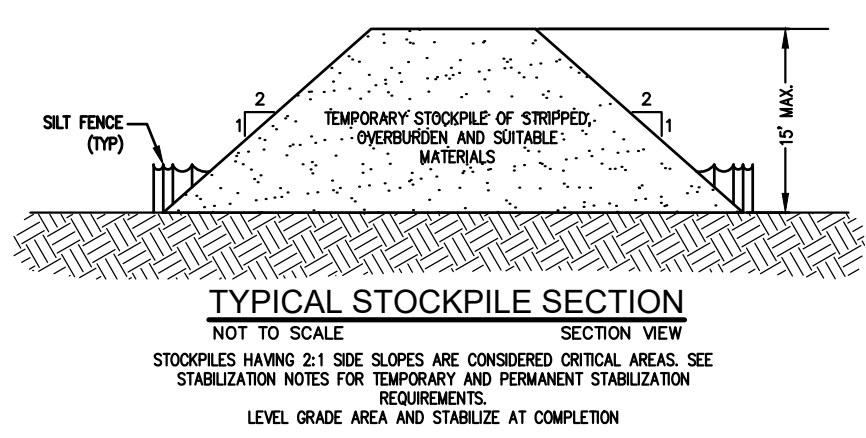

**CONSTRUCTION SEQUENCE SCHEDULE**

- CONSTRUCTION ACTIVITY**  
Construction Access— Construction entrance, construction routes, equipment parking areas construction takes place.
- SCHEDULE CONSIDERATION**  
First land-disturbing activity—Stabilize bare areas immediately with gravel & temporary vegetation or construction takes place.
- Install principal basins** after construction site is accessed. Install additional traps and barriers as needed during grading.
- Install key practices** after principal sediments traps and before land grading. Install additional runoff-control conveyance measures during grading.
- Where necessary**, stabilize stream banks as early as possible. Install principal runoff conveyance system with runoff-control measures. Install remainder of system after grading.
- Begin major clearing and grading** after principal & key runoff-control measures are installed. Clear borrow & disposal areas as needed. Install additional control measures as grading progresses. Mark trees & buffer areas for preservation.
- Apply temporary or permanent stabilization** measures immediately on all disturbed areas where work is delayed or complete.
- Install necessary erosion & sedimentation control practices** as work takes place.
- Stabilize all open areas**, including borrow & spoil areas. Remove & stabilize all temporary control measures.

**LAND GRADING CONSTRUCTION SPECIFICATIONS**

- Construct & maintain all erosion & sedimentation control practices & measures in accordance with the approved sedimentation control plan and construction schedule.
- Remove good topsoil from areas to be graded and filled, and preserve it for use in finishing the grading of all critical areas.
- Scarify areas to be topsoiled to a minimum depth of 2 inches before placing topsoil.
- Clear & grub areas to be filled to remove trees, vegetation, roots, or other objectionable material that would affect the planned stability of fill.
- Ensure that fill material is free of brush, rubbish, rocks, logs, stumps, building debris, and other materials inappropriate for constructing stable fills.
- Place all fill in layers not to exceed 9 inches in thickness, and compact the layers as required to reduce erosion, slippage, settlement, or other related problems.
- Do not incorporate frozen material or soft, muddy, or highly compressible materials into fill slopes.
- Do not place fill on a frozen foundation, due to possible subsidence and slippage.
- Keep diversions and other water conveyance measures free of sediment during all phases of development.
- Handle seeps or springs encountered during construction in accordance with approved methods.
- Following completion of any phase of grading, provide a groundcover (temporary or permanent) on all exposed slopes within 14 calendar days, or 7 calendar days in critical areas identified on the plan, and a permanent groundcover for all disturbed areas within 15 working days or 90 calendar days (whichever is shorter) following completion of construction or development.
- Provide adequate protection from erosion for all topsoil stockpiles, borrow areas, and spoil areas.

**PERMANENT SEEDING**

- The purpose of permanent seeding is to reduce erosion and decrease sediment yield from disturbed areas, and to permanently stabilize such areas in a manner that is economical, adaptable to site conditions, and allows selection of the most appropriate plant materials. These areas must be seeded or planted within 15 working days or 90 calendar days after final grade is reached, unless temporary stabilization is applied.
- PERMANENT SEEDING SPECIFICATIONS**  
Seeding Recommendations for Summer  
SEEDING DATES— April to July  
SEEDING MIXTURE  
Species Rate  
Common bermudagrass 10/1,000 sf (sprigs)  
1-2 lb/1,000 sf (seed)  
500 (See Sodding Notes)
- Seeding Recommendations for Early Fall through Early Spring**  
SEEDING DATES— August to March (early fall and spring recommended)  
Species Rate  
Kentucky 31 Tall Fescue 6 lb/1,000 sf (broadcast seed)
- SEEDING NOTES:**  
1. Sprig or sod. Moisture is essential during initial establishment. Sod must be kept watered for 2-3 weeks, but can be planted earlier or later than sprigs.  
2. Soil Amendments— It is highly recommended that soils be tested and amended as found necessary. If a soil is not tested follow these recommendations:  
Apply 3,000 lb/acre of ground agricultural limestone and 500 lb/acre of 10-10-10 starter fertilizer, or 50 lb/acre nitrogen from turf-type slow-release fertilizer. Add 25-50 lb/acre nitrogen at 2-3 week intervals through midsummer.  
3. Sprigging— Plant sprigs in furrows with a tractor-drawn transplanter, or broadcast by hand. (Not recommended for Tall Fescue)  
Furrows should be 4-6 inches deep and 2 feet apart. Place sprigs about 2 ft. apart in a row with one end at or above ground level.  
4. Broadcast at rates shown above, and press sprigs into the top 1/2-2 inches of soil with a disk set straight so that sprigs are not brought back toward the surface.  
5. Mulch— Do not mulch Bermuda Grass. For Tall Fescue seed, apply 4,000-lb/acre straw. Anchor straw by locking with asphalt, netting, or a disk with blades set nearly straight can be used as a mulch-anchoring tool.  
6. Maintenance— Water as needed. Mow bermuda to 3/4 to 1-inch height and tall fescue to 2.5 - 3.5 inch height. Topdress bermuda with 40 lb/acre nitrogen in April, 50 lb in May, 50 lb in June, 50 lb in July, and 25 lb in August. Top dress tall fescue in mid September, again in November and February with turf-grade 3-1-2 or 4-1-2 ratio turf-grade fertilizer. Fertilize with 1 lb of actual nitrogen per 1,000 sf. Do not fertilize tall fescue between Mid March and Early September.

**TEMPORARY SEEDING**

- The purpose of temporary seeding is to temporarily stabilize denuded areas that will not be brought to final grade or permanently seeded for a period of more than 14 calendar days, or 7 days in critical areas identified on the plan.
- TEMPORARY SEEDING SPECIFICATIONS**  
Seeding Recommendations for Late Winter & Early Spring  
SEEDING DATES— December 1 to April 15  
SEEDING MIXTURE  
Species Rate (lb/acre)  
Winter Rye (grain) 120 (Annual Ryegrass shall not be used)  
Annual Lespedeza 50  
(Kobe)  
\*omit Annual Lespedeza when duration of temporary cover is not to extend beyond June
- Soil Amendments—**  
Follow recommendations of soil tests or apply 2,000 lb/acre ground agricultural limestone and 750 lb/acre 10-10-10 fertilizer.
- Mulch—**  
Apply 4,000-lb/acre straw. Anchor straw by locking with asphalt, netting, or a mulch-anchoring tool. A disk with blades set nearly straight can be used as a mulch-anchoring tool.
- Maintenance—**  
Reroll if growth is not fully adequate. Reseed, fertilize and mulch immediately following erosion or other damage.
- Seeding Recommendations for Summer**  
SEEDING DATES— April 15 to August 15  
SEEDING MIXTURE  
Species Rate (lb/acre)  
German Millet 40
- Soil Amendments—**  
Follow recommendations of soil tests or apply 2,000 lb/acre ground agricultural limestone and 750 lb/acre 10-10-10 fertilizer.
- Mulch—**  
Apply 4,000-lb/acre straw. Anchor straw by locking with asphalt, netting, or a mulch-anchoring tool. A disk with blades set nearly straight can be used as a mulch-anchoring tool.
- Maintenance—**  
Reroll if growth is not fully adequate. Reseed, fertilize and mulch immediately following erosion or other damage.
- Seeding Recommendations for Fall**  
SEEDING DATES— August 15 to December 30  
SEEDING MIXTURE  
Species Rate (lb/acre)  
Winter Rye (grain) 120
- Soil Amendments—**  
Follow recommendations of soil tests or apply 2,000 lb/acre ground agricultural limestone and 1,000 lb/acre 10-10-10 fertilizer.
- Mulch—**  
Apply 4,000-lb/acre straw. Anchor straw by locking with asphalt, netting, or a mulch-anchoring tool. A disk with blades set nearly straight can be used as a mulch-anchoring tool.
- Maintenance—**  
Repair and refertilize damaged areas immediately. Topdress with 50 lb/acre of nitrogen in March. If it is necessary to extend temporary cover beyond June 15, overseed with 50 lb/acre Kobe Lespedeza in late February or Early March.

**SODDING**

- The purpose of permanent seeding is to prevent erosion and damage from sediment and runoff by stabilizing the soil surface with permanent vegetation for the purpose of:
- the provision of immediate vegetative cover in critical areas
  - to stabilize disturbed areas with a suitable plant material that cannot be established by seed.
  - to stabilize drainage ways & channels and other areas of concentrated flow where flow velocities will not exceed that specified grass lining.
- SODDING SPECIFICATIONS**  
-Sod should be machine cut at a uniform depth of 1/2-2 inches  
-Sod should not have been cut in excessively wet or dry weather.  
-Sections of sod should be standard size as determined by the supplier, uniform, and uniform.  
-Sections of sod should be strong enough to support their own weight and retain their size and shape when lifted by one end.  
-Harvest, delivery, and installation of sod should take place within a period of 36 hours.
- Soil Amendments—**  
Apply lime and fertilizer according to soil tests or apply 2 tons/acre of pulverized agricultural limestone and 1,000 lb/acre 10-10-10 fertilizer in the fall, or 5-10-10 in spring.
- Prior to laying sod**, clear the soil surface of trash, debris, roots, branches, stones, and clods larger than 2 inches in diameter. Fill or level low spots in order to avoid standing water. Rake or harrow the site to achieve a smooth and level final grade. Complete soil preparation by rolling or outpicking to firm soil.
- Sod Installation—**  
1. Moistening the sod after it is unrolled helps maintain viability. Store in shade during installation.  
2. Rake the soil surface to break the crust just before laying sod. During the summer, lightly irrigate the soil, immediately before laying sod to cool the soil and reduce root burning & dieback.  
3. Do not sod on grave, frozen soils, or soils that have been treated recently with sterilants or herbicides.  
4. Lay the first row of sod in a straight line with subsequent rows placed parallel to and butting lightly against each other. Stagger strips in a brick-like pattern. Be sure that the sod is not stretched or overlapped and that all joints are butted lightly to prevent voids. Use a knife or sharp spade to trim and fill irregular shaped areas.  
5. Install strips of sod with their longest dimension perpendicular to the slope. On slopes of 3:1 or greater, or wherever erosion may be a problem, secure sod with pegs or staples.  
6. As sodding of clearly defined areas is completed, roll sod to provide good contact between roots and soil.  
7. After rolling, irrigate until the soil is wet 4 inches below the sod.  
8. Keep sodded areas moist to a depth of 4 inches until the grass takes root. This can be determined by tugging on the sod.  
9. Mowing should not be attempted until the sod is firmly rooted, usually 2-3 weeks.
- Sodded Waterways**  
1. Prepare soil as described above.  
2. Lay sod strips perpendicular to the direction of flow, with the lateral joints staggered in a brick-like pattern. Butt edges tightly together.
- Maintenance—**  
After the first week, water as necessary to maintain adequate moisture in the root zone & prevent dormancy of the sod.
- Do not remove more than one-third of the shoot in any one mowing. Grass height should be maintained between 2-3 inches unless otherwise specified.
- After first growing season, established sod requires fertilization, and may also require lime. Follow soil test recommendations.

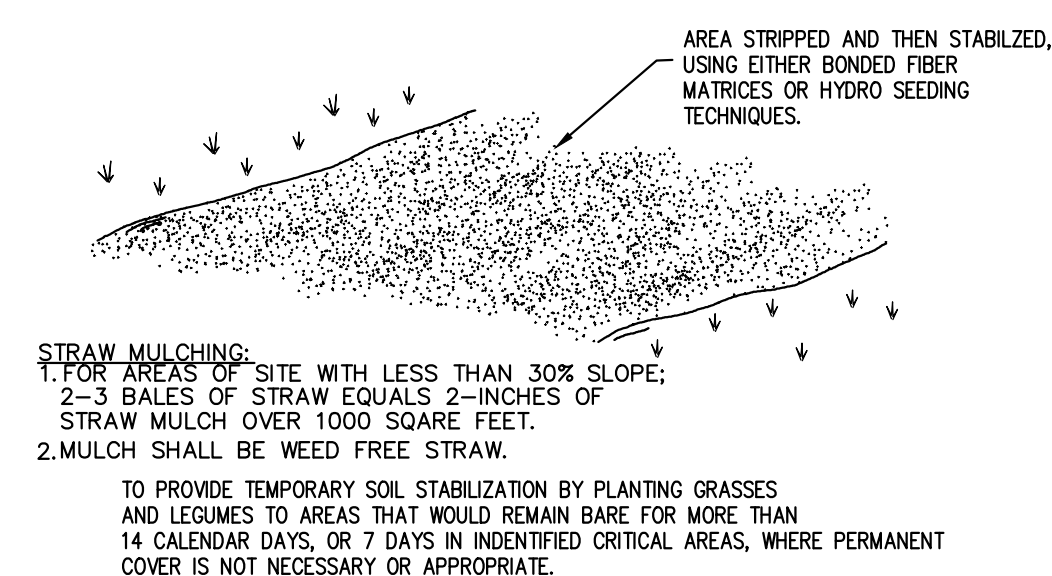
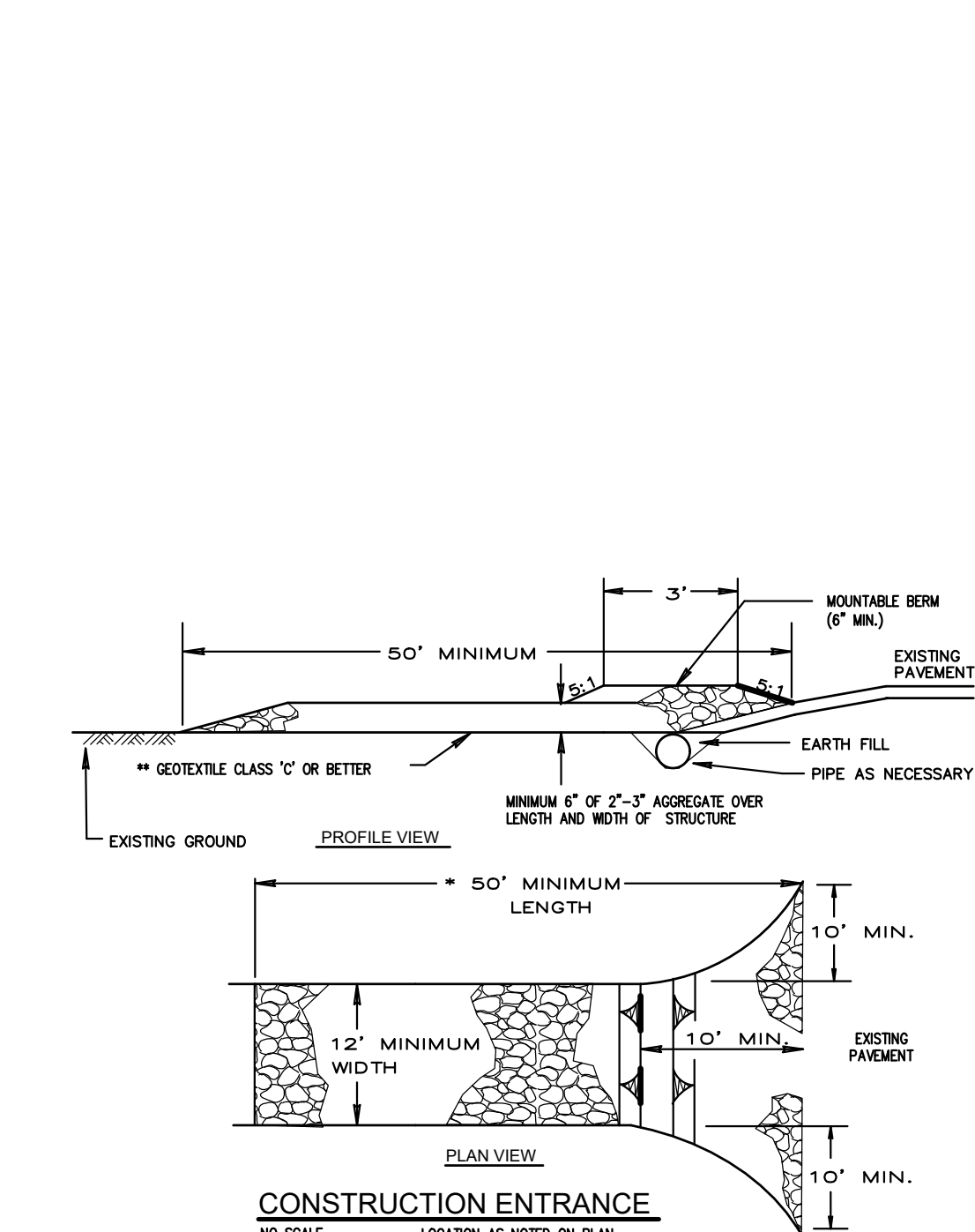

**LAND DISTURBANCE & STABILIZATION DETAIL**

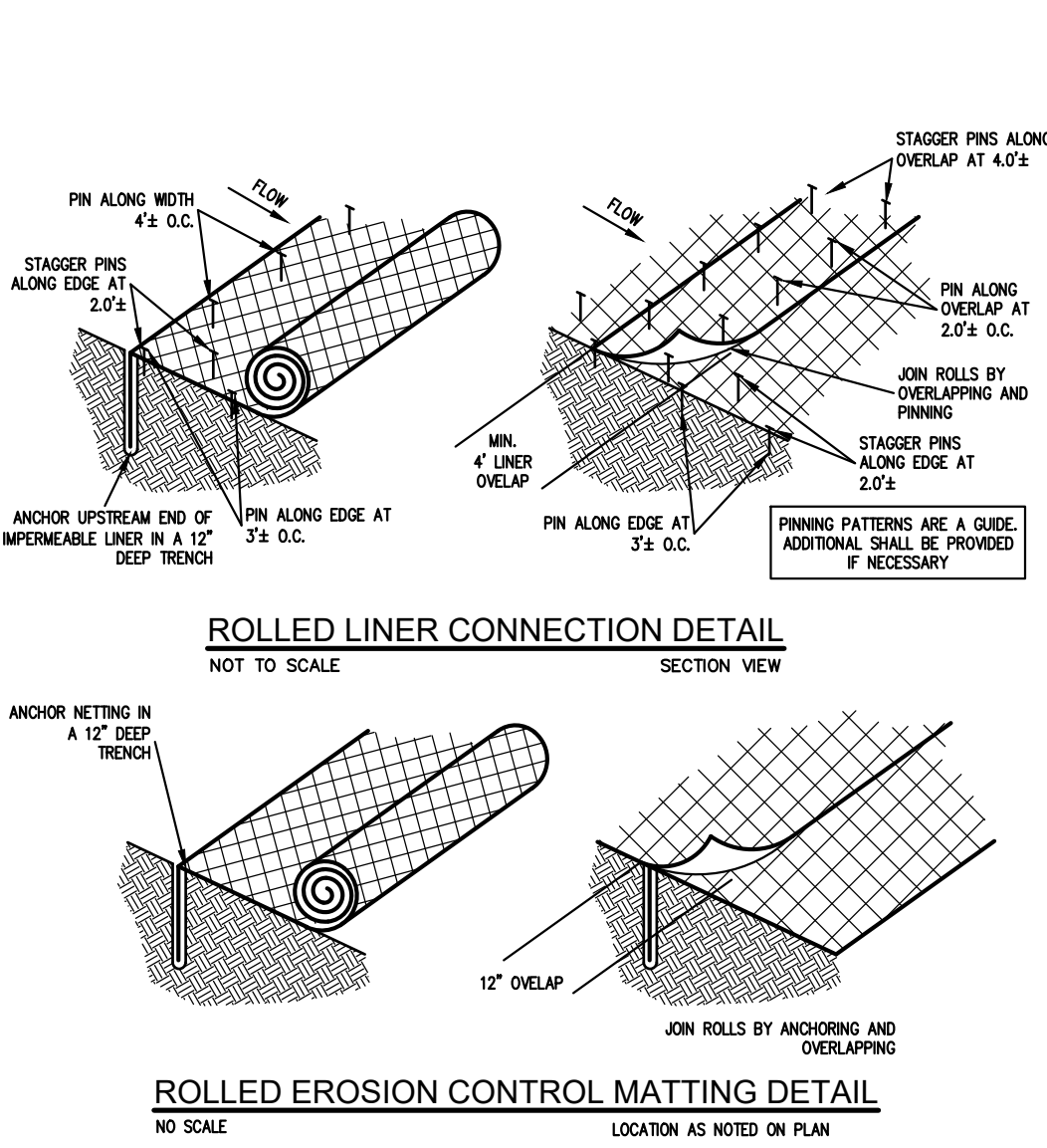

**E&S/DEMO NOTES:**

- ANY AND ALL MATERIAL OR DEBRIS TRACKED ONTO A PUBLIC OR PRIVATE ROAD SURFACE WILL BE CLEANED THOROUGHLY AT THE END OF EACH DAY. SEDIMENT SHALL BE REMOVED FROM ROADS BY SHOVELING OR SWEEPING AND BE TRANSPORTED TO A SEDIMENT CONTROLLED DISPOSAL AREA.
- ALL EXCAVATED MATERIAL SHALL BE DISPOSED OF IN A LAWFUL MANNER.
- DEMOLITION AND CONSTRUCTION ACTIVITIES ARE NOT TO DISTURB NOR ENDOCRACH UPON ADJACENT PROPERTIES AT ANY TIME DURING CONSTRUCTION.
- ALL ITEMS OF WORK NECESSARY TO COMPLETE THIS PROJECT SHALL BE IN COMPLIANCE WITH ALL STATE AND LOCAL CODES.
- ANY PAVEMENT REMOVAL REQUIRED SHALL BE REMOVED TO NEAT STRAIGHT LINES.
- THE CONTRACTOR SHALL BE RESPONSIBLE FOR REPLACING WITH MATCHING MATERIALS, ANY PAVEMENT, CONCRETE, CURBS, ETC. THAT MUST BE CUT OR THAT ARE DAMAGED DURING CONSTRUCTION.
- WHEN UNSUITABLE MATERIAL FOR FOUNDATION, SUBGRADE, OR OTHER PURPOSES OCCURS WITHIN THE LIMITS OF CONSTRUCTION, THE CONTRACTOR SHALL EXCAVATE SUCH MATERIAL AND BACKFILL WITH APPROVED SUITABLE MATERIAL. THE EXTENT OF UNDERCUTTING AND BACKFILLING TO BE DETERMINED BY THE OWNER'S SOILS ENGINEERING CONSULTANT.
- ANY TREE ROOT BALL REMOVAL MUST IMMEDIATELY BE FOLLOWED BY BACKFILLING, STABILIZATION, AND SEEDING.
- THE CONTRACTOR SHALL INSTALL "TRUCKS ENTERING HIGHWAY" (48"x48" ORANGE AND BLACK) WARNING SIGNS ON 6"x6" WOODEN GROUND MOUNTED POSTS. THESE SIGNS WILL BE INSTALLED 500 FEET IN ADVANCE OF ALL APPROVED CONSTRUCTION ACCESS/ENTRANCE POINTS.
- DURING CONSTRUCTION THE CONTRACTOR SHALL PROVIDE ADEQUATE CONVEYANCE OF RUNOFF TO ENSURE PONDING DOES NOT OCCUR AND SEDIMENT LADEN WATER DOES NOT LEAVE THE SITE.
- THE INTERCONNECTED STORMWATER PIPE SYSTEM MUST BE CLEANED OF SEDIMENT AFTER ALL UPSTREAM DISTURBANCE HAS TAKEN PLACE, AND IS PERMANENTLY STABILIZED OR AT THE CIVIL INSPECTOR'S DISCRETION.
- ALL TEMPORARY SWALES SHALL BE STABILIZED IMMEDIATELY FOLLOWING INSTALLATION WITH TEMPORARY OR PERMANENT VEGETATION.
- DURING CONSTRUCTION, THE POND WILL BE UTILIZED AS AN EROSION & SEDIMENT CONTROL SEDIMENT BASIN. THE OUTLET STRUCTURE WILL ALSO REQUIRE SURFACE SKIMMER DEVICES AS DETAILED. ONCE CONSTRUCTION IS COMPLETE AND THE SITE IS PROPERLY STABILIZED THE PONDS SHALL BE CLEANED AND RESTORED TO ITS DESIGN SPECIFICATIONS AND THE BANKS PERMANENTLY STABILIZED WITHIN 7 DAYS.

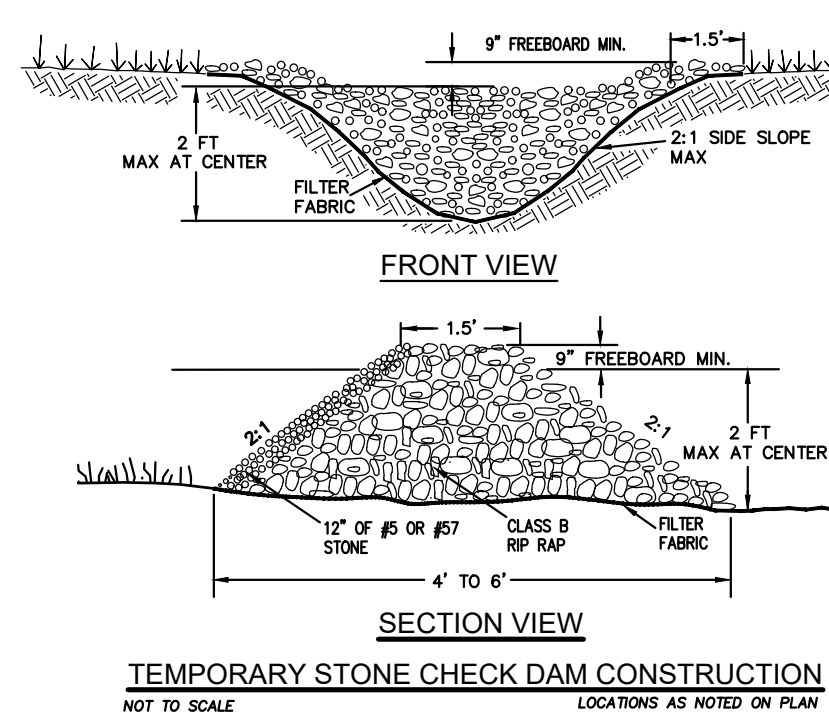
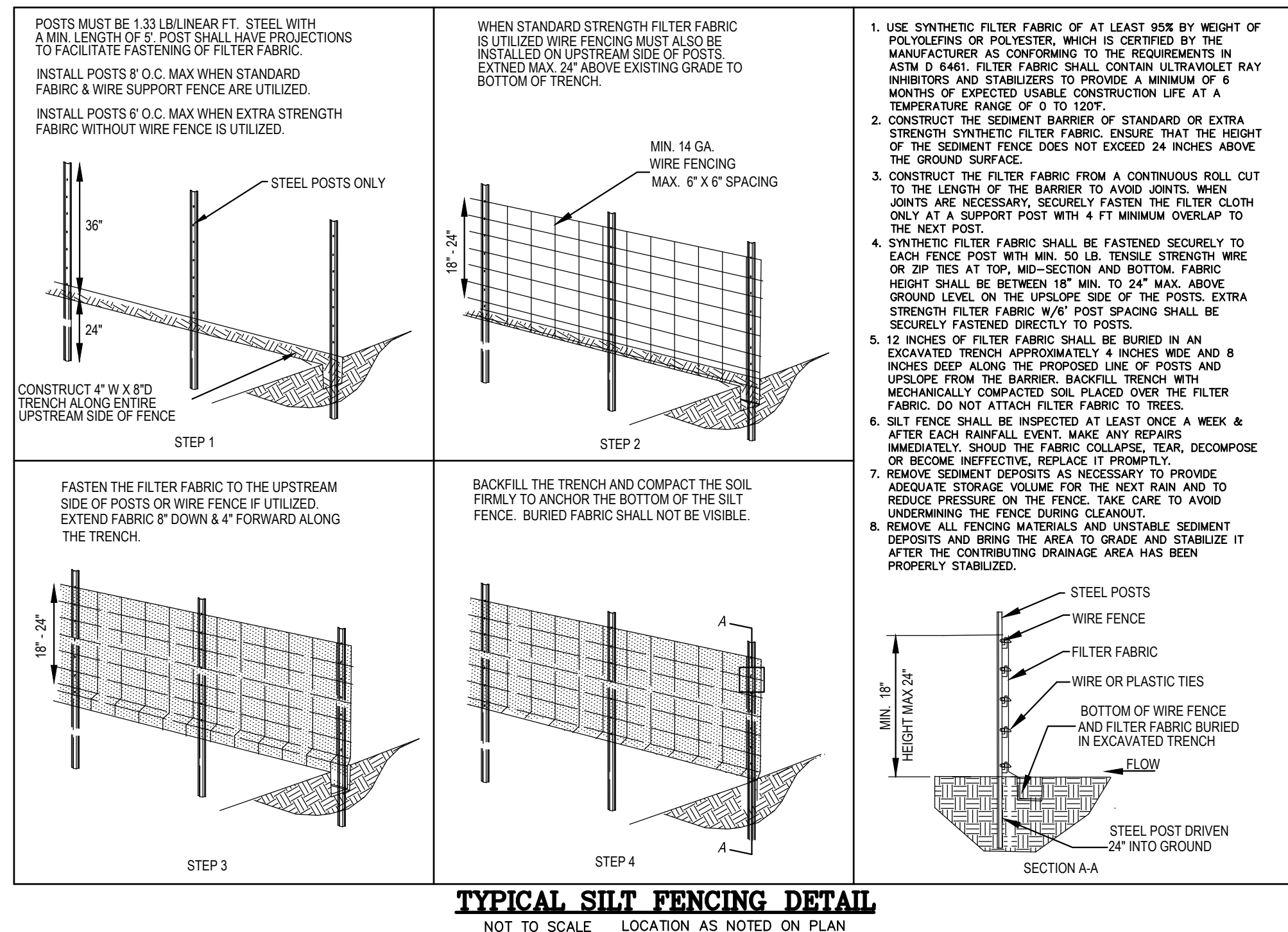

**FINAL DESIGN  
NOT RELEASED FOR  
CONSTRUCTION**

I:\Projects\24102 New Bridge Creek Subdivision\Engineering\Drawings & Exhibits\DWG\24102\_Cover & Detail.dwg [C-503] - Friday, April 03, 2026, 4:52pm

**ENGINEERS | SCIENTISTS | SURVEYORS**

5032 ROUSE DRIVE, SUITE 200 | VIRGINIA BEACH, VA 23462 | 757-490-0266 | MSAONLINE.COM

**DOUGLAS M. WHITE**  
ENGINEER  
NO. 035335  
STATE OF NORTH CAROLINA

DESIGNED	JTP	CHECKED	CSA
DRAWN	JTP	DWV	DATE
APPROVED	03/17/26		

REVISIONS

NO.	DESCRIPTION	DATE

E&S CONTROL NOTES & DETAILS OF

**NEW BRIDGE CREEK**

A 35 LOT RESIDENTIAL SUBDIVISION

CURRITUCK COUNTY NORTH CAROLINA

MOYOCK TOWNSHIP

SHEET

**C-503**

29 of 32 Sheets

SCALE: AS SHOWN

PROJ. NO.: 24102

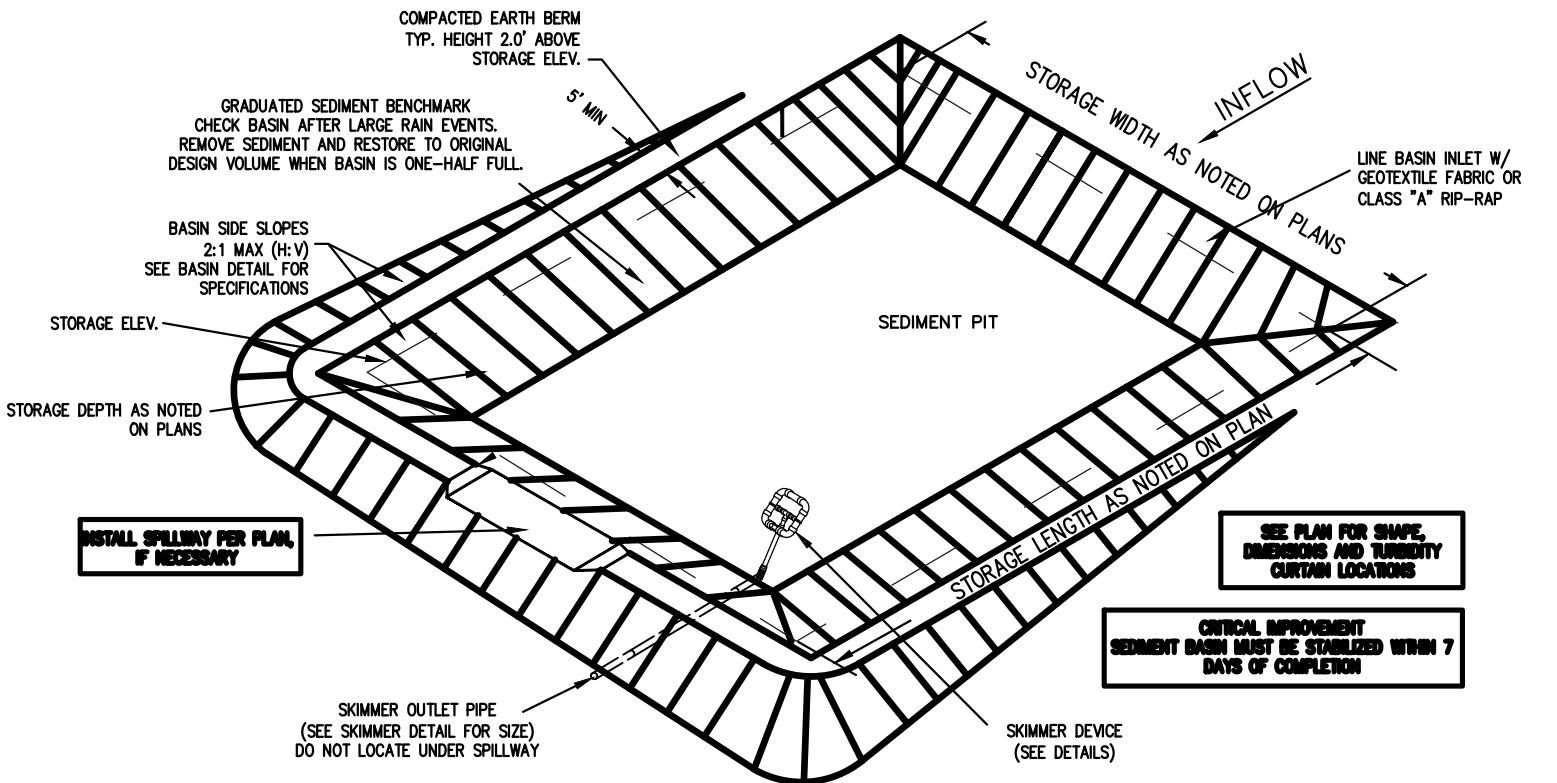

TYPICAL DEWATERING AND SEDIMENT BASIN DETAIL

- NOT TO SCALE
- CONSTRUCTION SPECIFICATIONS
1. PLACE TEMPORARY SEDIMENT CONTROL MEASURES BELOW BASIN AS NEEDED. CLEAR, GRUB AND STRIP AREA. PROPERLY DISPOSE OF OBJECTIONABLE MATERIAL.
  2. CONSTRUCT SEDIMENTATION IN LIFTS OF 9 INCHES AND MAXIMUM CONTACT. ENSURE MATERIAL IS FREE OF ROOTS, WOOD AND OTHER OBJECTIONABLE MATERIALS.
  3. SHAPE BASIN TO SPECIFIED DIMENSIONS.
  4. PLACE OUTLET BARRIERS ON FIRM, SMOOTH IMPERVIOUS SOIL FOUNDATION. DO NOT USE SAND, GRAVEL OR CRUSHED STONE. PLACE FILL MATERIAL AROUND PIPE SPILLWAY IN 4 INCH LIFTS AND COMPACT TO MATCH ADJACENT EMBANKMENT.
  5. ASSEMBLE THE SKIMMER FOLLOWING MANUFACTURER'S INSTRUCTIONS OR AS DESIGNED.
  6. PROMOTE STONE OR OTHER BED TO SET SKIMMER ON AND PREVENT SETTLEMENT INTO MUD. LAY ASSEMBLED SKIMMER ON BED WITH FLEXIBLE JOINT AT THE INLET OF THE OUTLET BARREL PIPE. ATTACHED SKIMMER AND OUTLET BARREL BE SURE TO ATTACH A ROPE TO THE SKIMMER AND ANCHOR IT TO THE SIDE OF THE BASIN. THIS WILL BE USED TO ACCESS THE SKIMMER FOR REMOVAL AND MAINTENANCE.
  7. INSTALL SPILLWAY IN UNDISTURBED SOIL TO THE GREATEST EXTENT PRACTICABLE. ACHIEVE SPILLWAY DIMENSIONS PROVIDED. LINE SPILLWAY WITH LAMINATED PLASTIC OR IMPERVIOUS GEOTEXTILE FABRIC. SECURE EDGES WITH 6-INCH STAPLES OR PINS. FABRIC MUST BE ENOUGH TO COVER BOTTOM AND SIDES WITH ONE PIECE. NO JOINTS OR SPICES. FABRIC MUST BE LOW ENOUGH TO EXTEND UP, OVER AND DOWN ACROSS THE SPILLWAY AND EXTEND ONTO STABLE GROUND. IF NECESSARY, MULTIPLE FULL WIDTH LENGTHS MAY BE USED WITH UPPER SECTIONS OVERLAPPING LOWER SECTIONS.
  8. WATER MUST DISCHARGE INTO BASIN IN A MANNER TO PREVENT EROSION. LINE INLET WITH GEOTEXTILE FABRIC OR RP-RAP STONE. USE TEMPORARY SLOPE DRAINS OR DIVERSION WITH OUTLET PROTECTION TO DIVERT RUNOFF TO THE UPPER END OF THE SEDIMENT BASIN.
  9. INSTALL TURBIDITY CURTAINS PER DETAILS PROVIDED.
  10. AFTER ALL DISTURBED AREAS TRIBUTARY TO THE BASIN HAVE BEEN PERMANENTLY STABILIZED, REMOVE THE STRUCTURE AND ALL THE UNSTABLE SEDIMENT. SMOOTH THE AREA TO BLEND WITH ADJACENT AREAS AND STABILIZE PROPERTY.

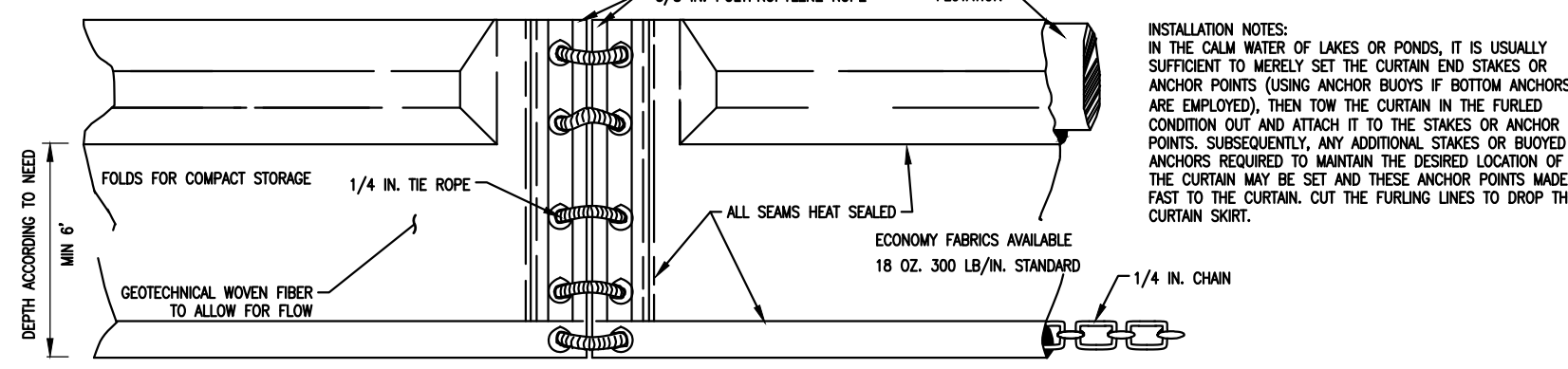

TYPICAL TURBIDITY CURTAIN DETAIL

- NOT TO SCALE
- TURBIDITY CURTAIN SPECIFICATIONS:
1. MAINTAIN THE FILTER CURTAIN DURING THE PROJECT TO ENSURE THE CONTINUOUS PROTECTION OF THE WATERCOURSE.
  2. REPAIR THE FLOATING BARRIER AS NECESSARY USING REPAIR KITS AVAILABLE FROM THE MANUFACTURER. FOLLOW THE MANUFACTURER'S INSTRUCTIONS TO ENSURE THE ADEQUACY OF THE REPAIR.
  3. WHEN THE CURTAIN IS NO LONGER REQUIRED, REMOVE THE CURTAIN AND RELATED COMPONENTS TO MINIMIZE TURBIDITY. PRIOR TO REMOVAL, COORDINATION WITH THE APPROPRIATE AUTHORITY IS RECOMMENDED.
  4. ENSURE THE REMAINING SEDIMENT IS SUFFICIENTLY SETTLED BEFORE REMOVING THE CURTAIN.
  5. TAKE CARE TO PROTECT THE SKIRT FROM DAMAGE AS THE TURBIDITY CURTAIN IS DRAGGED FROM THE WEIRS.
  6. THE SITE SELECTED TO BRING THE CURTAIN ASHORE SHOULD BE FREE OF SHARP ROCKS, BROKEN CEMENT, DEBRIS, AND OTHER HAZARDS TO MINIMIZE DAMAGE WHEN HAULING THE CURTAIN OVER THE AREA.
  7. IF THE CURTAIN HAS A DEEP SPOIL, IT CAN BE FURTHER PROTECTED BY RUNNING A SMALL BOAT ALONG TO LENGTH WITH A CREW INSTALLING FURLING LINES BEFORE ATTEMPTING TO REMOVE THE CURTAIN FROM THE WATER.
  8. SEDIMENT MAY BE REMOVED AND THE ORIGINAL WATERCOURSE DEPTH (OR PLAN ELEVATION) RESTORED. TRANSPORT ANY SPOILS TO AN UPLAND AREA AND STABILIZE THE SPOILS. TO ENSURE COMPLIANCE WITH PERMIT CONDITIONS COORDINATION WITH THE APPROPRIATE AUTHORITY IS RECOMMENDED.

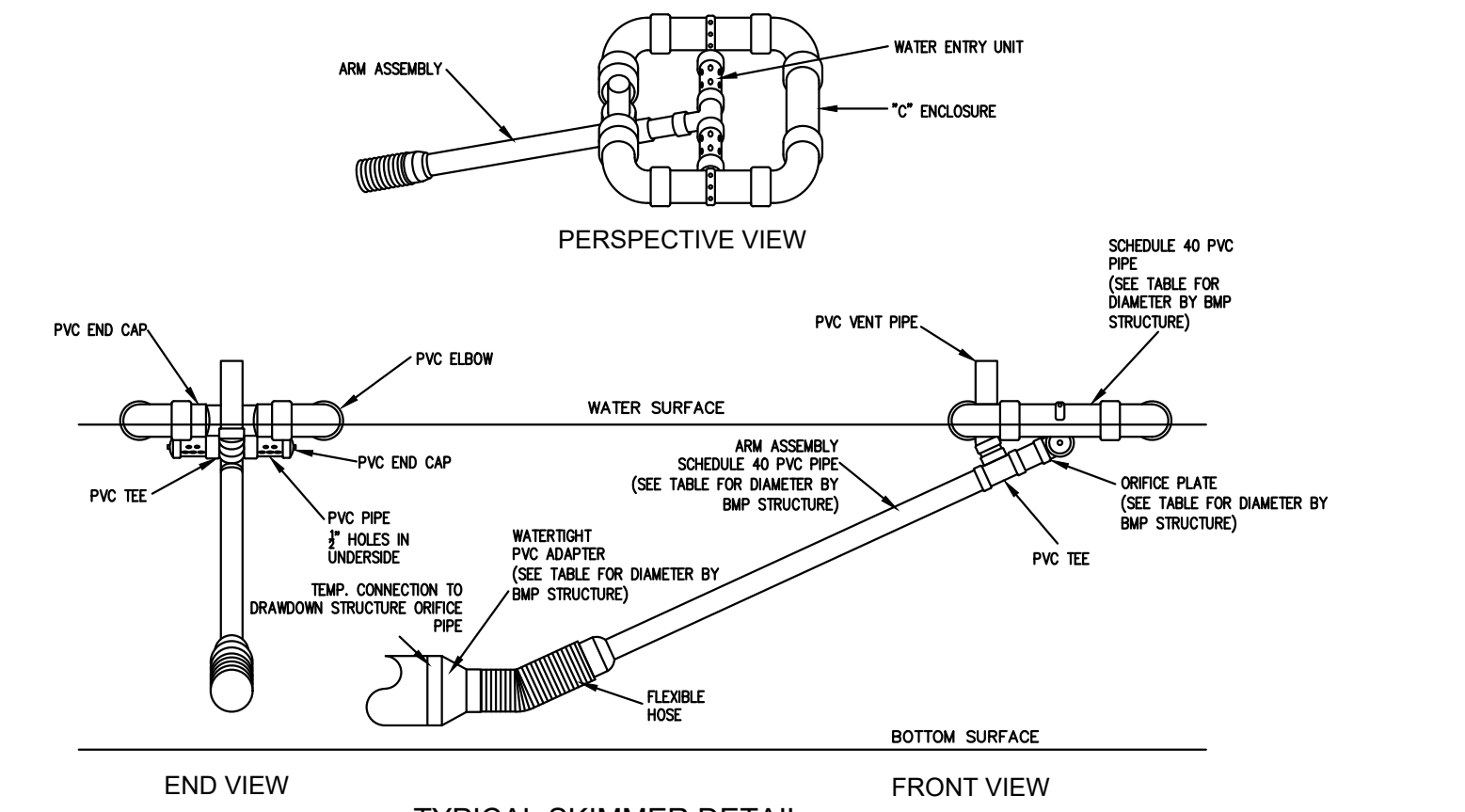

TYPICAL SKIMMER DETAIL

NOT TO SCALE. LOCATION AS NOTED ON PLAN

SKIMMER #	PVC ARM AND ENCLOSURE DIA.	ORIFICE PLATE DIA.	PVC ADAPTER	CLEANOUT STORAGE ELEV. & VOLUME
#1	6 INCHES	3 INCHES	6 INCH X OCS-1	-19.50, 25834 CF
#2	6 INCHES	3 INCHES	6 INCH X OCS-2	-8.00, 20585 CF

SKIMMER TABLE

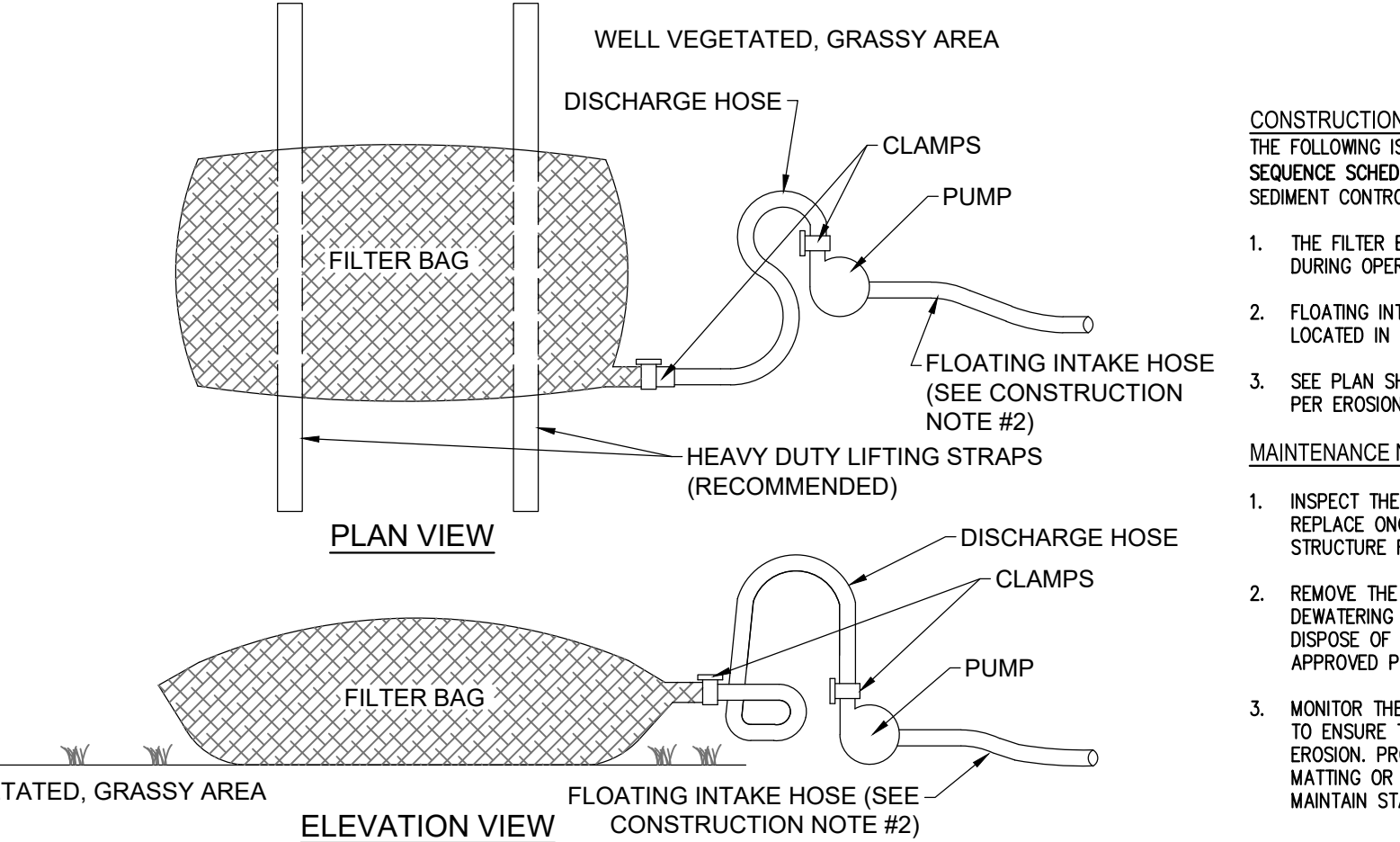

SEDIMENT FILTER BAG DETAIL

NOT TO SCALE

- CONSTRUCTION NOTES:
- THE FOLLOWING IS IN ADDITION TO THE "CONSTRUCTION SEQUENCE SCHEDULE" PROVIDED UNDER THE EROSION AND SEDIMENT CONTROL SPECIFICATIONS.
1. THE FILTER BAG SHALL BE CONTINUOUSLY MONITORED DURING OPERATION.
  2. FLOATING INTAKE FOR PUMPING OPERATIONS SHALL BE LOCATED IN THE SKIMMER CELL.
  3. SEE PLAN SHEETS FOR SEDIMENT FILTER BAG LOCATIONS PER EROSION & SEDIMENT CONTROL PHASE.
- MAINTENANCE NOTES:
1. INSPECT THE FILTERING DEVICES DAILY AND REPAIR OR REPLACE ONCE THE SEDIMENT BUILDUP PREVENTS THE STRUCTURE FROM FUNCTIONING AS DESIGNED.
  2. REMOVE THE ACCUMULATED SEDIMENT FROM THE DEWATERING DEVICE. SPREAD ON SITE, AND STABILIZE OR DISPOSE OF AT AN APPROVED DISPOSAL SITE AS PER APPROVED PLAN.
  3. MONITOR THE DEWATERING STRUCTURE DURING OPERATION TO ENSURE THAT THE DISCHARGE IS NOT CAUSING EROSION. PROVIDE SOIL STABILIZATION BLANKETS AND MATING OR COMPOST FILTER SOCKS AS NEEDED TO MAINTAIN STABILIZED AREAS DOWNSTREAM OF STRUCTURE.

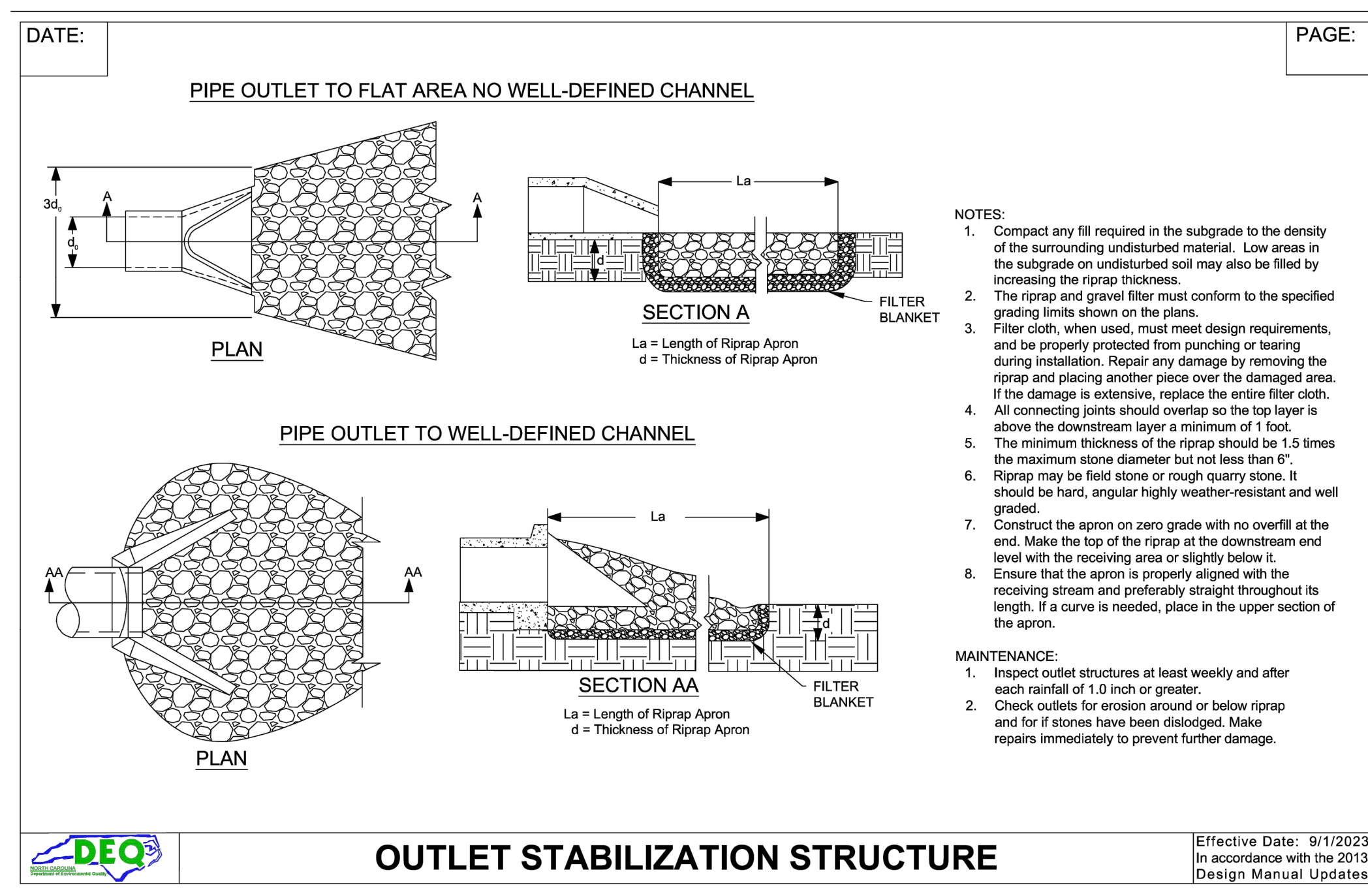

OUTLET STABILIZATION STRUCTURE

STRUCTURE ID (SEE STORM SCHEDULE ON SHEET CG101)	APRON LENGTH (La) (FT)	APRON WIDTH AT PIPE OUTLET (FT)	APRON WIDTH AT OUTLET END (FT)	APRON THICKNESS (d) (IN)	MEDIAN STONE DIAMETER (m)	MAXIMUM STONE DIAMETER (m)
ST-7	18	6	9.2	9.45	4.2	6.3
ST-8, ST-9	SEE PLAN SHEET FOR AREA	SEE PLAN SHEET FOR AREA	SEE PLAN SHEET FOR AREA	21.6	9.6	14.4
ST-10, ST-11	SEE PLAN SHEET FOR AREA	SEE PLAN SHEET FOR AREA	SEE PLAN SHEET FOR AREA	21.6	9.6	14.4
OP-1	15	6	8	10.8	4.8	7.2
ST-14	16	6	8.4	13.5	6	9
ST-15, ST-16	SEE PLAN SHEET FOR AREA	SEE PLAN SHEET FOR AREA	SEE PLAN SHEET FOR AREA	13.5	6	9
ST-17, ST-18	SEE PLAN SHEET FOR AREA	SEE PLAN SHEET FOR AREA	SEE PLAN SHEET FOR AREA	13.5	6	9
ST-19	20	7.5	10.5	17.55	7.8	11.7
OP-1	15	6	8	9.1	3.6	5.4

OUTLET STABILIZATION TABLE

WATER MAIN SPECIFICATIONS AND DETAILS FOR THIS PLAN, INCLUDING ALL MATERIALS AND INSTALLATION METHODS SHALL BE PROVIDED, INSTALLED, TESTED AND ACCEPTED IN ACCORDANCE WITH THE "STANDARD SPECIFICATIONS AND DETAILS FOR THE CURRITUCK COUNTY WATER DEPARTMENT AND THE SOUTHERN OUTER BANKS WATER SYSTEM" AS APPROVED BY NCDEQ-DWR-PWS, SERIAL NUMBER 11-00630, LATEST REVISION.

A MINIMUM OF 36" OF COVER SHALL BE MAINTAINED OVER THE INSTALLED WATER MAIN.

A MINIMUM OF 24" OF SEPARATION SHALL BE PROVIDED FROM BOTTOM OF STORM DRAIN TO TOP OF WATER MAIN.

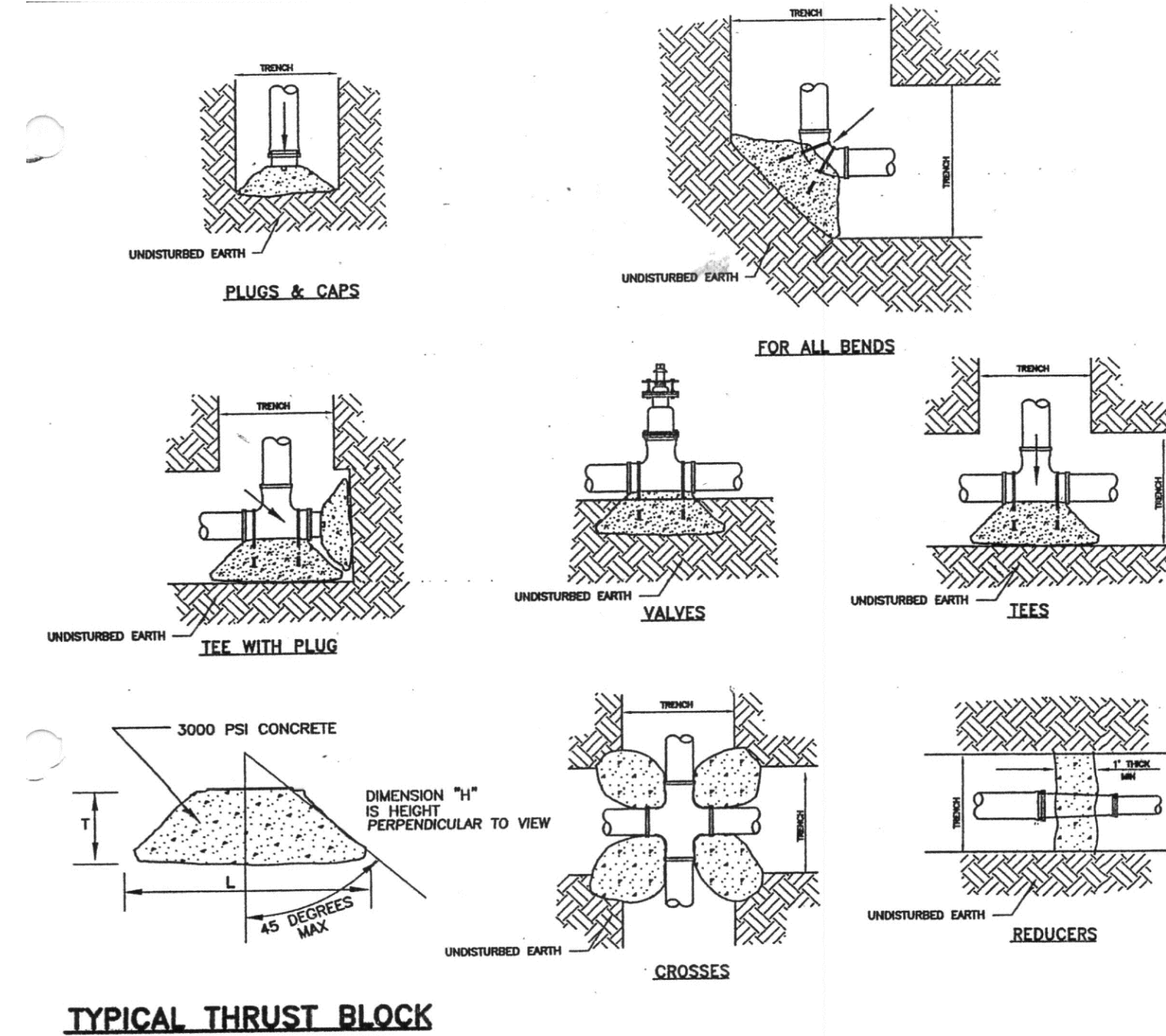

TYPICAL THRUST BLOCK

ANCHOR ROD SIZES

PIPE SIZE	ROD SIZE
4" THRU 6"	#4
8" THRU 10"	#6
12" THRU 18"	#8

CONCRETE THRUST BLOCK

PIPE SIZE	FITTING	L (FT.)	H (FT.)	T (FT.)
2 - 3 - 4	TEE OR BLOCK	2.0	1.0	1.0
2 - 3 - 4	90	2.0	1.5	1.0
2 - 3 - 4	45	1.5	1.0	1.0
2 - 3 - 4	22 1/2	1.0	1.0	1.0
6	TEE OR BLOCK	2.0	2.0	1.0
6	90	3.0	2.0	1.5
6	45	2.0	1.5	1.0
6	22 1/2	1.5	1.0	1.0
8	TEE OR BLOCK	3.0	2.5	1.5
8	90	4.0	2.5	2.0
8	45	2.5	2.0	1.5
8	22 1/2	2.0	1.5	1.0
12	TEE OR BLOCK	4.0	4.0	2.0
12	90	5.0	4.5	2.5
12	45	4.0	3.0	2.0
12	22 1/2	3.0	2.0	1.5

NOTE: THIS TABLE BASED ON WATER PRESSURE 150 PSI SOIL BRG. 1500 #/SQ. FT. TO 2000 #/SQ. FT.

FINAL DESIGN  
NOT RELEASED FOR  
CONSTRUCTION

**MSA** ENGINEERS | SCIENTISTS | SURVEYORS

5032 ROUSE DRIVE, SUITE 200 | VIRGINIA BEACH, VA 23462 | 757.490.9264 | MSAONLINE.COM

PROFESSIONAL ENGINEER  
JULIUS M. WELLS  
03/17/26  
03535

DESIGNED: JTP  
DRAWN: JTP  
CHECKED: DMW  
APPROVED: CSA  
DATE: 03/17/26

E&S CONTROL AND MISCELLANEOUS DETAILS  
OF  
NEW BRIDGE CREEK  
A 35 LOT RESIDENTIAL SUBDIVISION  
CURRITUCK COUNTY NORTH CAROLINA  
MOYOCK TOWNSHIP

SHEET  
**C-504**  
30 of 32 Sheets  
SCALE: AS SHOWN  
PROJ. NO.: 24102

**GROUND STABILIZATION AND MATERIALS HANDLING PRACTICES FOR COMPLIANCE WITH THE NCG01 CONSTRUCTION GENERAL PERMIT**

Implementing the details and specifications on this plan sheet will result in the construction activity being considered compliant with the Ground Stabilization and Materials Handling sections of the NCG01 Construction General Permit (Sections E and F, respectively). The permittee shall comply with the Erosion and Sediment Control plan approved by the delegated authority having jurisdiction. All details and specifications shown on this sheet may not apply depending on site conditions and the delegated authority having jurisdiction.

**SECTION E: GROUND STABILIZATION**

Required Ground Stabilization Timeframes		
Site Area Description	Stabilize within this many calendar days after ceasing land disturbance	Timeframe variations
(a) Perimeter dikes, swales, ditches, and perimeter slopes	7	None
(b) High Quality Water (HQW) Zones	7	None
(c) Slopes steeper than 3:1	7	If slopes are 10' or less in length and are not steeper than 2:1, 14 days are allowed
(d) Slopes 3:1 to 4:1	14	-7 days for slopes greater than 50' in length and with slopes steeper than 4:1 -7 days for perimeter dikes, swales, ditches, perimeter slopes and HQW Zones -10 days for Falls Lake Watershed
(e) Areas with slopes flatter than 4:1	14	-7 days for perimeter dikes, swales, ditches, perimeter slopes and HQW Zones -10 days for Falls Lake Watershed unless there is zero slope

**Note:** After the permanent cessation of construction activities, any areas with temporary ground stabilization shall be converted to permanent ground stabilization as soon as practicable but in no case longer than 90 calendar days after the last land disturbing activity. Temporary ground stabilization shall be maintained in a manner to render the surface stable against accelerated erosion until permanent ground stabilization is achieved.

**GROUND STABILIZATION SPECIFICATION**

Stabilize the ground sufficiently so that rain will not dislodge the soil. Use one of the techniques in the table below:

Temporary Stabilization	Permanent Stabilization
<ul style="list-style-type: none"> <li>Temporary grass seed covered with straw or other mulches and tackifiers</li> <li>Hydroseeding</li> <li>Rolled erosion control products with or without temporary grass seed</li> <li>Appropriately applied straw or other mulch</li> <li>Plastic sheeting</li> </ul>	<ul style="list-style-type: none"> <li>Permanent grass seed covered with straw or other mulches and tackifiers</li> <li>Geotextile fabrics such as permanent soil reinforcement matting</li> <li>Hydroseeding</li> <li>Shrubs or other permanent plantings covered with mulch</li> <li>Uniform and evenly distributed ground cover sufficient to restrain erosion</li> <li>Structural methods such as concrete, asphalt or retaining walls</li> <li>Rolled erosion control products with grass seed</li> </ul>

**POLYACRYLAMIDES (PAMS) AND FLOCCULANTS**

- Select flocculants that are appropriate for the soils being exposed during construction, selecting from the *NC DWR List of Approved PAMS/Flocculants*.
- Apply flocculants at or before the inlets to Erosion and Sediment Control Measures.
- Apply flocculants at the concentrations specified in the *NC DWR List of Approved PAMS/Flocculants* and in accordance with the manufacturer's instructions.
- Provide ponding area for containment of treated Stormwater before discharging offsite.
- Store flocculants in leak-proof containers that are kept under storm-resistant cover or surrounded by secondary containment structures.

**EQUIPMENT AND VEHICLE MAINTENANCE**

- Maintain vehicles and equipment to prevent discharge of fluids.
- Provide drip pans under any stored equipment.
- Identify leaks and repair as soon as feasible, or remove leaking equipment from the project.
- Collect all spent fluids, store in separate containers and properly dispose as hazardous waste (recycle when possible).
- Remove leaking vehicles and construction equipment from service until the problem has been corrected.
- Bring used fuels, lubricants, coolants, hydraulic fluids and other petroleum products to a recycling or disposal center that handles these materials.

**LITTER, BUILDING MATERIAL AND LAND CLEARING WASTE**

- Never bury or burn waste. Place litter and debris in approved waste containers.
- Provide a sufficient number and size of waste containers (e.g dumpster, trash receptacle) on site to contain construction and domestic wastes.
- Locate waste containers at least 50 feet away from storm drain inlets and surface waters unless no other alternatives are reasonably available.
- Locate waste containers on areas that do not receive substantial amounts of runoff from upland areas and does not drain directly to a storm drain, stream or wetland.
- Cover waste containers at the end of each workday and before storm events or provide secondary containment. Repair or replace damaged waste containers.
- Anchor all lightweight items in waste containers during times of high winds.
- Empty waste containers as needed to prevent overflow. Clean up immediately if containers overflow.
- Dispose waste off-site at an approved disposal facility.
- On business days, clean up and dispose of waste in designated waste containers.

**PAINT AND OTHER LIQUID WASTE**

- Do not dump paint and other liquid waste into storm drains, streams or wetlands.
- Locate paint washouts at least 50 feet away from storm drain inlets and surface waters unless no other alternatives are reasonably available.
- Contain liquid wastes in a controlled area.
- Containment must be labeled, sized and placed appropriately for the needs of site.
- Prevent the discharge of soaps, solvents, detergents and other liquid wastes from construction sites.

**PORTABLE TOILETS**

- Install portable toilets on level ground, at least 50 feet away from storm drains, streams or wetlands unless there is no alternative reasonably available. If 50 foot offset is not attainable, provide relocation of portable toilet behind silt fence or place on a gravel pad and surround with sand bags.
- Provide staking or anchoring of portable toilets during periods of high winds or in high foot traffic areas.
- Monitor portable toilets for leaking and properly dispose of any leaked material. Utilize a licensed sanitary waste hauler to remove leaking portable toilets and replace with properly operating unit.

**EARTHEN STOCKPILE MANAGEMENT**

- Show stockpile locations on plans. Locate earthen-material stockpile areas at least 50 feet away from storm drain inlets, sediment basins, perimeter sediment controls and surface waters unless it can be shown no other alternatives are reasonably available.
- Protect stockpile with silt fence installed along toe of slope with a minimum offset of five feet from the toe of stockpile.
- Provide stable stone access point when feasible.
- Stabilize stockpile within the timeframes provided on this sheet and in accordance with the approved plan and any additional requirements. Soil stabilization is defined as vegetative, physical or chemical coverage techniques that will restrain accelerated erosion on disturbed soils for temporary or permanent control needs.

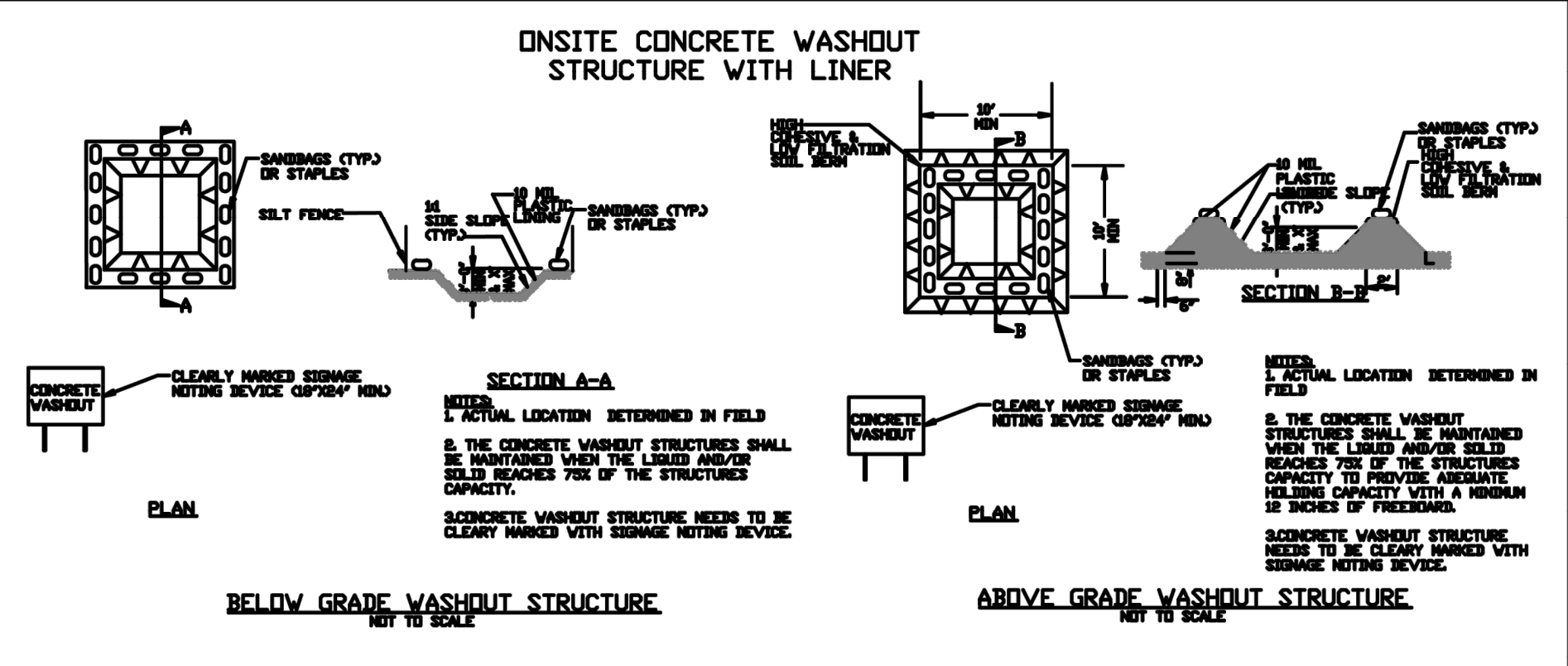

**CONCRETE WASHOUTS**

- Do not discharge concrete or cement slurry from the site.
- Dispose of, or recycle settled, hardened concrete residue in accordance with local and state solid waste regulations and at an approved facility.
- Manage washout from mortar mixers in accordance with the above item and in addition place the mixer and associated materials on impervious barrier and within lot perimeter silt fence.
- Install temporary concrete washouts per local requirements, where applicable. If an alternate method or product is to be used, contact your approval authority for review and approval. If local standard details are not available, use one of the two types of temporary concrete washouts provided on this detail.
- Do not use concrete washouts for dewatering or storing defective curb or sidewalk sections. Stormwater accumulated within the washout may not be pumped into or discharged to the storm drain system or receiving surface waters. Liquid waste must be pumped out and removed from project.
- Locate washouts at least 50 feet from storm drain inlets and surface waters unless it can be shown that no other alternatives are reasonably available. At a minimum, install protection of storm drain inlet(s) closest to the washout which could receive spills or overflow.
- Locate washouts in an easily accessible area, on level ground and install a stone entrance pad in front of the washout. Additional controls may be required by the approving authority.
- Install at least one sign directing concrete trucks to the washout within the project limits. Post signage on the washout itself to identify this location.
- Remove leavings from the washout when at approximately 75% capacity to limit overflow events. Replace the tarp, sand bags or other temporary structural components when no longer functional. When utilizing alternative or proprietary products, follow manufacturer's instructions.
- At the completion of the concrete work, remove remaining leavings and dispose of in an approved disposal facility. Fill pit, if applicable, and stabilize any disturbance caused by removal of washout.

**HERBICIDES, PESTICIDES AND RODENTICIDES**

- Store and apply herbicides, pesticides and rodenticides in accordance with label restrictions.
- Store herbicides, pesticides and rodenticides in their original containers with the label, which lists directions for use, ingredients and first aid steps in case of accidental poisoning.
- Do not store herbicides, pesticides and rodenticides in areas where flooding is possible or where they may spill or leak into wells, stormwater drains, ground water or surface water. If a spill occurs, clean area immediately.
- Do not stockpile these materials onsite.

**HAZARDOUS AND TOXIC WASTE**

- Create designated hazardous waste collection areas on-site.
- Place hazardous waste containers under cover or in secondary containment.
- Do not store hazardous chemicals, drums or bagged materials directly on the ground.

**NCG01 GROUND STABILIZATION AND MATERIALS HANDLING**

**EFFECTIVE: 04/01/19**

**FINAL DESIGN  
NOT RELEASED FOR  
CONSTRUCTION**

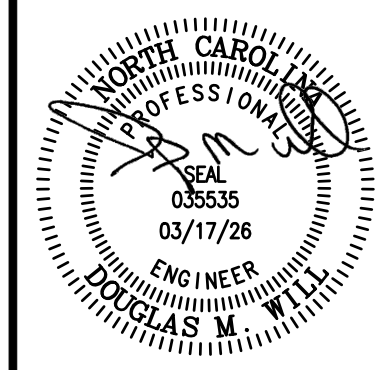
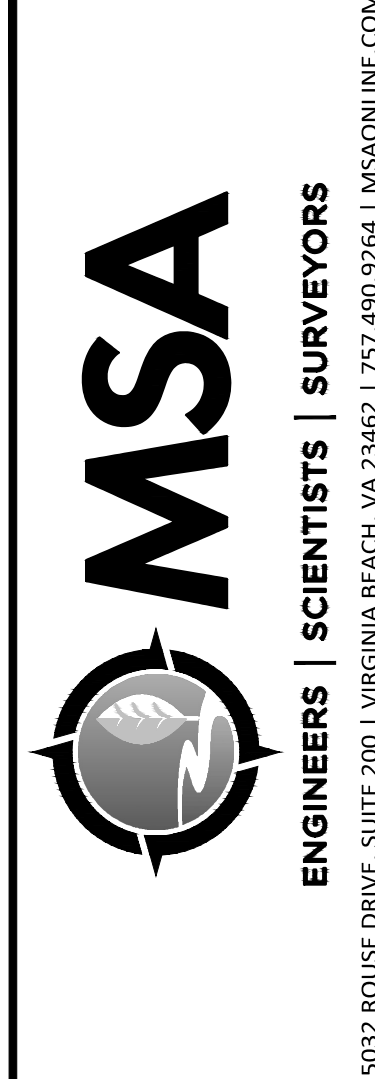

DESIGNED	JTP	DATE	03/17/26
DRAWN	JTP		
CHECKED	DMW		
APPROVED	CSA		

REVISION	NO.	DESCRIPTION

NCG01-GROUND STABILIZATION & MATERIALS HANDLING  
OF  
**NEW BRIDGE CREEK**  
A 35 LOT RESIDENTIAL SUBDIVISION  
CURRITUCK COUNTY NORTH CAROLINA

I:\Projects\24102 New Bridge Creek Subdivision\Engineering\Drawings & Exhibits\DWG\24102\_Cover & Detail.dwg [C-505] - Friday, April 03, 2026, 4:52pm

**PART III  
SELF-INSPECTION, RECORDKEEPING AND REPORTING**

**SECTION A: SELF-INSPECTION**

Self-inspections are required during normal business hours in accordance with the table below. When adverse weather or site conditions would cause the safety of the inspection personnel to be in jeopardy, the inspection may be delayed until the next business day on which it is safe to perform the inspection. In addition, when a storm event of equal to or greater than 1.0 inch occurs outside of normal business hours, the self-inspection shall be performed upon the commencement of the next business day. Any time when inspections were delayed shall be noted in the Inspection Record.

Inspect	Frequency (during normal business hours)	Inspection records must include:
(1) Rain gauge maintained in good working order	Daily	Daily rainfall amounts. If no daily rain gauge observations are made during weekend or holiday periods, and no individual-day rainfall information is available, record the cumulative rain measurement for those unattended days (and this will determine if a site inspection is needed). Days on which no rainfall occurred shall be recorded as "zero." The permittee may use another rain-monitoring device approved by the Division.
(2) E&SC Measures	At least once per 7 calendar days and within 24 hours of a rain event ≥ 1.0 inch in 24 hours	1. Identification of the measures inspected, 2. Date and time of the inspection, 3. Name of the person performing the inspection, 4. Indication of whether the measures were operating properly, 5. Description of maintenance needs for the measure, 6. Description, evidence, and date of corrective actions taken.
(3) Stormwater discharge outfalls (SDCs)	At least once per 7 calendar days and within 24 hours of a rain event ≥ 1.0 inch in 24 hours	1. Identification of the discharge outfalls inspected, 2. Date and time of the inspection, 3. Name of the person performing the inspection, 4. Evidence of indicators of stormwater pollution such as oil sheen, floating or suspended solids or discoloration, 5. Indication of visible sediment leaving the site, 6. Description, evidence, and date of corrective actions taken.
(4) Perimeter of site	At least once per 7 calendar days and within 24 hours of a rain event ≥ 1.0 inch in 24 hours	If visible sedimentation is found outside site limits, then a record of the following shall be made: 1. Actions taken to clean up or stabilize the sediment that has left the site limits, 2. Description, evidence, and date of corrective actions taken, and 3. An explanation as to the actions taken to control future releases.
(5) Streams or wetlands onsite or offsite (where accessible)	At least once per 7 calendar days and within 24 hours of a rain event ≥ 1.0 inch in 24 hours	If the stream or wetland has increased visible sedimentation or a stream has visible increased turbidity from the construction activity, then a record of the following shall be made: 1. Description, evidence and date of corrective actions taken, and 2. Records of the required reports to the appropriate Division Regional Office per Part III, Section C, Item (2)(a) of this permit.
(6) Ground stabilization measures	After each phase of grading	1. The phase of grading (installation of perimeter E&SC measures, clearing and grubbing, installation of storm drainage facilities, completion of all land-disturbing activity, construction or redevelopment, permanent ground cover). 2. Documentation that the required ground stabilization measures have been provided within the required timeframe or an assurance that they will be provided as soon as possible.

NOTE: The rain inspection resets the required 7 calendar day inspection requirement.

**PART III  
SELF-INSPECTION, RECORDKEEPING AND REPORTING**

**SECTION B: RECORDKEEPING**

**1. E&SC Plan Documentation**

The approved E&SC plan as well as any approved deviation shall be kept on the site. The approved E&SC plan must be kept up-to-date throughout the coverage under this permit. The following items pertaining to the E&SC plan shall be kept on site and available for inspection at all times during normal business hours.

Item to Document	Documentation Requirements
(a) Each E&SC measure has been installed and does not significantly deviate from the locations, dimensions and relative elevations shown on the approved E&SC plan.	Initial and date each E&SC measure on a copy of the approved E&SC plan or complete, date and sign an inspection report that lists each E&SC measure shown on the approved E&SC plan. This documentation is required upon the initial installation of the E&SC measures or if the E&SC measures are modified after initial installation.
(b) A phase of grading has been completed.	Initial and date a copy of the approved E&SC plan or complete, date and sign an inspection report to indicate completion of the construction phase.
(c) Ground cover is located and installed in accordance with the approved E&SC plan.	Initial and date a copy of the approved E&SC plan or complete, date and sign an inspection report to indicate compliance with approved ground cover specifications.
(d) The maintenance and repair requirements for all E&SC measures have been performed.	Complete, date and sign an inspection report.
(e) Corrective actions have been taken to E&SC measures.	Initial and date a copy of the approved E&SC plan or complete, date and sign an inspection report to indicate the completion of the corrective action.

**2. Additional Documentation to be Kept on Site**

In addition to the E&SC plan documents above, the following items shall be kept on the site and available for inspectors at all times during normal business hours, unless the Division provides a site-specific exemption based on unique site conditions that make this requirement not practical:

- (a) This General Permit as well as the Certificate of Coverage, after it is received.
- (b) Records of inspections made during the previous twelve months. The permittee shall record the required observations on the Inspection Record Form provided by the Division or a similar inspection form that includes all the required elements. Use of electronically-available records in lieu of the required paper copies will be allowed if shown to provide equal access and utility as the hard-copy records.

**3. Documentation to be Retained for Three Years**

All data used to complete the e-NOI and all inspection records shall be maintained for a period of three years after project completion and made available upon request. [40 CFR 122.41]

**PART III  
SELF-INSPECTION, RECORDKEEPING AND REPORTING**

**SECTION C: REPORTING**

**1. Occurrences that Must be Reported**

Permittees shall report the following occurrences:

- (a) Visible sediment deposition in a stream or wetland.
- (b) Oil spills if:
  - They are 25 gallons or more,
  - They are less than 25 gallons but cannot be cleaned up within 24 hours,
  - They cause sheen on surface waters (regardless of volume), or
  - They are within 100 feet of surface waters (regardless of volume).
- (c) Releases of hazardous substances in excess of reportable quantities under Section 311 of the Clean Water Act (Ref: 40 CFR 110.3 and 40 CFR 117.3) or Section 102 of CERCLA (Ref: 40 CFR 302.4) or G.S. 143-215.85.
- (d) Anticipated bypasses and unanticipated bypasses.
- (e) Noncompliance with the conditions of this permit that may endanger health or the environment.

**2. Reporting Timeframes and Other Requirements**

After a permittee becomes aware of an occurrence that must be reported, he shall contact the appropriate Division regional office within the timeframes and in accordance with the other requirements listed below. Occurrences outside normal business hours may also be reported to the Department's Environmental Emergency Center personnel at (800) 858-0368.

Occurrence	Reporting Timeframes (After Discovery) and Other Requirements
(a) Visible sediment deposition in a stream or wetland	<ul style="list-style-type: none"> <li>• <b>Within 24 hours</b>, an oral or electronic notification.</li> <li>• <b>Within 7 calendar days</b>, a report that contains a description of the sediment and actions taken to address the cause of the deposition. Division staff may waive the requirement for a written report on a case-by-case basis.</li> <li>• If the stream is named on the <a href="#">NC 303(d) list</a> as impaired for sediment-related causes, the permittee may be required to perform additional monitoring, inspections or apply more stringent practices if staff determine that additional requirements are needed to assure compliance with the federal or state impaired-waters conditions.</li> </ul>
(b) Oil spills and release of hazardous substances per Item 1(b)-(c) above	<ul style="list-style-type: none"> <li>• <b>Within 24 hours</b>, an oral or electronic notification. The notification shall include information about the date, time, nature, volume and location of the spill or release.</li> </ul>
(c) Anticipated bypasses [40 CFR 122.41(m)(3)]	<ul style="list-style-type: none"> <li>• <b>A report at least ten days before the date of the bypass, if possible.</b> The report shall include an evaluation of the anticipated quality and effect of the bypass.</li> </ul>
(d) Unanticipated bypasses [40 CFR 122.41(m)(3)]	<ul style="list-style-type: none"> <li>• <b>Within 24 hours</b>, an oral or electronic notification.</li> <li>• <b>Within 7 calendar days</b>, a report that includes an evaluation of the quality and effect of the bypass.</li> </ul>
(e) Noncompliance with the conditions of this permit that may endanger health or the environment [40 CFR 122.41(l)(7)]	<ul style="list-style-type: none"> <li>• <b>Within 24 hours</b>, an oral or electronic notification.</li> <li>• <b>Within 7 calendar days</b>, a report that contains a description of the noncompliance, and its causes; the period of noncompliance, including exact dates and times, and if the noncompliance has not been corrected, the anticipated time noncompliance is expected to continue; and steps taken or planned to reduce, eliminate, and prevent reoccurrence of the noncompliance. [40 CFR 122.41(l)(6)].</li> <li>• Division staff may waive the requirement for a written report on a case-by-case basis.</li> </ul>

**PART II, SECTION G, ITEM (4)  
DRAW DOWN OF SEDIMENT BASINS FOR MAINTENANCE OR CLOSE OUT**

Sediment basins and traps that receive runoff from drainage areas of one acre or more shall use outlet structures that withdraw water from the surface when these devices need to be drawn down for maintenance or close out unless this is infeasible. The circumstances in which it is not feasible to withdraw water from the surface shall be rare (for example, times with extended cold weather). Non-surface withdrawals from sediment basins shall be allowed only when all of the following criteria have been met:

- (a) The E&SC plan authority has been provided with documentation of the non-surface withdrawal and the specific time periods or conditions in which it will occur. The non-surface withdrawal shall not commence until the E&SC plan authority has approved these items,
- (b) The non-surface withdrawal has been reported as an anticipated bypass in accordance with Part III, Section C, Item (2)(c) and (d) of this permit,
- (c) Dewatering discharges are treated with controls to minimize discharges of pollutants from stormwater that is removed from the sediment basin. Examples of appropriate controls include properly sited, designed and maintained dewatering tanks, weir tanks, and filtration systems,
- (d) Vegetated, upland areas of the sites or a properly designed stone pad is used to the extent feasible at the outlet of the dewatering treatment devices described in Item (c) above,
- (e) Velocity dissipation devices such as check dams, sediment traps, and riprap are provided at the discharge points of all dewatering devices, and
- (f) Sediment removed from the dewatering treatment devices described in Item (c) above is disposed of in a manner that does not cause deposition of sediment into waters of the United States.



**NCG01 SELF-INSPECTION, RECORDKEEPING AND REPORTING**

**EFFECTIVE: 04/01/19**

**FINAL DESIGN  
NOT RELEASED FOR  
CONSTRUCTION**

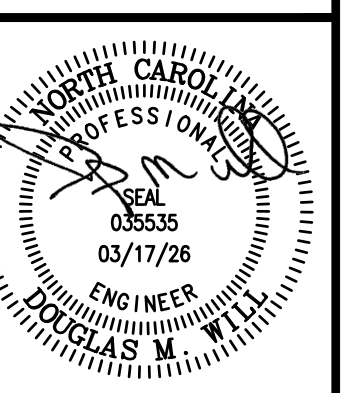

DESIGNED	JTP	DATE	03/17/26
DRAWN	JTP	CHECKED	
CHECKED	DMW	APPROVED	
APPROVED	CSA		

REVISION	NO.	DESCRIPTION

NCC01—SELF INSPECTION, RECORDKEEPING & REPORTING  
OF  
**NEW BRIDGE CREEK**  
A 35 LOT RESIDENTIAL SUBDIVISION  
CURRITUCK COUNTY NORTH CAROLINA  
MOYOCK TOWNSHIP