

**CONTRACT DOCUMENTS**

FOR

**REPLACE EXISTING 24" STORMWATER PIPE**

**With Alternate Bid for**

**BRIDGE OPTION**

**GOVERNMENT CENTER STORMWATER  
SYSTEM**

**Currituck, NC**

Currituck County

February 16, 2015



## **TABLE OF CONTENTS**

NOTICE TO BIDDERS

INSTRUCTIONS TO BIDDERS

BID FORM

INDEPENDENT CONTRACTOR'S AGREEMENT

E-VERIFY FORM

CONSTRUCTION NOTES

CONSTRUCTION DRAWINGS

## **NOTICE TO BIDDERS**

Bids will be received until 4:00pm on **MARCH 12, 2015** at the Currituck County Engineer's Office, Currituck County Courthouse, 153 Courthouse Road, Suite 302, Currituck, NC 27929, for the following project:

**REPLACE EXISTING 24" STORMWATER PIPE  
With Alternate Bid for  
BRIDGE OPTION**

**GOVERNMENT CENTER STORMWATER SYSTEM  
Currituck, NC**

The project includes removing an existing 24" corrugated metal pipe (CMP) stormwater culvert that has rusted and created a sink hole at the ground surface. The culvert is approximately 100' long and is buried 10' deep between two stormwater ponds. The culvert is to be dug up and replaced with new 24" reinforced concrete pipe (RCP).

An alternate bid will be received for a Bridge Option which would involve installing a wooden bridge over a new swale to connect the two stormwater ponds (in lieu of digging up the pipe).

Obtain plans from and direct questions to:

Eric T. Weatherly, PE

Phone (252) 232-6035

[Eric.Weatherly@CurrituckCountyNC.gov](mailto:Eric.Weatherly@CurrituckCountyNC.gov)

This will be an informal bid. The bids will be evaluated and contract will be awarded in accordance with the statutory requirements. All bidders must meet the licensing requirements under Chapter 87 of the N.C. General Statutes. Small Business Entities, Women Owned Businesses and Minority Owned Businesses are encouraged to submit bids. The County reserves the right to reject any and all bids and to accept such bids as appears in its judgment to be in the best interest of the County. The County reserves the right to waive any informality.

## **INSTRUCTIONS TO BIDDERS**

**February 16, 2015**

Scope of work shall include all materials and installation of 100 lf - 24" RCP stormwater culvert connecting two existing stormwater ponds and an alternate bid for a new swale and wooden bridge to connect the two existing stormwater ponds.

### **NOTES:**

- All bidders must meet the licensing requirements under Chapter 87 of the N.C. General Statutes.
- Contractor is responsible for visiting site and understanding scope of work.
- The project shall be completed within 45 days of the Notice to Proceed.
- The Contractor awarded the project will be required to:
  - Execute the Independent Contractor Agreement (sample attached)
  - Execute the E-Verify Statement (attached)
  - Provide a form W-9
  - Provide Certificate of Insurance for general liability and workers' compensation coverage with Currituck County named as a certificate holder
- Provide a 1 year warranty on all work.
- Contractor is responsible for locating all utilities.
- Bonds are not required

Bids will be received until 4:00pm on March 12, 2015 at the Currituck County Engineer's Office, Currituck County Courthouse, 153 Courthouse Road, Suite 302, Currituck, NC 27929. ALL BIDS ARE TO BE MARKED: "Replace Existing 24" Stormwater Pipe with alternate Bridge Option at County Government Center".

Any questions, problems or suggestions please contact:

Eric T. Weatherly, PE

Eric.Weatherly@CurrituckCountyNC.gov

Phone: 252-232-6035

**BID FORM (page 1 of 2)**

**REPLACE EXISTING 24" STORMWATER PIPE  
With Alternate Bid for  
BRIDGE OPTION**

**GOVERNMENT CENTER STORMWATER SYSTEM  
Currituck, NC**

The Bidder agrees to perform all the work as shown on the Contract Documents, and to furnish all labor, tools, equipment, transportation and all other incidentals necessary for completion of **REPLACE EXISTING 24" STORMWATER PIPE With Alternate Bid for BRIDGE OPTION for the GOVERNMENT CENTER STORMWATER SYSTEM.**

In compliance with the Notice to Bidders, Instructions to Bidders, the Contract Documents which include the Independent Contractor's Agreement and the contract drawings and project specifications titled **"REPLACE EXISTING 24" STORMWATER PIPE With Alternate Bid for BRIDGE OPTION for the GOVERNMENT CENTER STORMWATER SYSTEM."** dated \_\_\_\_\_, and all addenda issued to date, all of which are part of this proposal, the undersigned hereby proposes to furnish and install all materials, labor, and equipment called for by, and in strict accordance with, said Contract Documents, for the complete Scope of Work indicated:

Complete Scope of Work:

**REPLACE EXISTING 24" STORMWATER PIPE**

**GRAND TOTAL**

(Lump Sum) \$ \_\_\_\_\_

\_\_\_\_\_  
Write out total dollar amount in words

**BRIDGE OPTION WITH SWALE**

**GRAND TOTAL**

(Lump Sum) \$ \_\_\_\_\_

\_\_\_\_\_  
Write out total dollar amount in words

**BID FORM (page 2 of 2)**

**REPLACE EXISTING 24" STORMWATER PIPE  
With Alternate Bid  
BRIDGE OPTION  
for the  
GOVERNMENT CENTER STORMWATER SYSTEM  
Currituck, NC**

- The bid amount shall be shown in both words and figures. In case of discrepancy, the amount in words shall govern.
- The above prices shall include labor, materials, overhead, profit, insurance, bonds, taxes, site repair, clean-up, etc., to cover the finished work of the several kinds called for.
- The Bidder agrees that this bid shall be valid and may not be withdrawn for a period of 60 calendar days after the scheduled closing time for receiving bids.
- Owner shall choose either option of replacing the culvert or installing a bridge.

Bidder has examined copies of all the Bidding Documents and of the following Addenda (receipt of all which is hereby acknowledged):

Addendum Date:

\_\_\_\_\_  
\_\_\_\_\_  
\_\_\_\_\_  
\_\_\_\_\_

Addendum Number:

\_\_\_\_\_  
\_\_\_\_\_  
\_\_\_\_\_  
\_\_\_\_\_

Respectfully submitted this \_\_\_\_\_ day of \_\_\_\_\_, 2015.

\_\_\_\_\_  
Name of Firm

\_\_\_\_\_  
Contractors License No.

\_\_\_\_\_  
Signature

\_\_\_\_\_  
Telephone No.

\_\_\_\_\_  
Printed Name and Title

\_\_\_\_\_  
Fax No.

\_\_\_\_\_  
Address

\_\_\_\_\_  
Address

\_\_\_\_\_  
Email Address

## **EXAMPLE**

### **INDEPENDENT CONTRACTOR AGREEMENT**

THIS AGREEMENT is made the \_\_\_\_ day of \_\_\_\_\_, 2015 between the **County of Currituck** (hereinafter “County”) and \_\_\_\_\_ [Contractor], (hereinafter “Contractor”).

#### RECITALS

County is a body corporate and politic of the State of North Carolina with the duties and powers set forth in Chapter 153A of the North Carolina General Statutes.

Contractor represents that it is duly qualified to perform business, and otherwise to transact business in North Carolina.

IT IS THEREFORE AGREED as follows:

1. Scope of Work. Contractor agrees to perform the following services for County:  
**Work as outlined in the Contract Documents for (REPLACE EXISTING 24” STORMWATER PIPE) or (BRIDGE OPTION) for the GOVERNMENT CENTER STORMWATER SYSTEM Currituck, NC, (hereinafter “the Services”).**
2. Compensation. Contractor will be paid for its Services by County as follows:

\_\_\_\_\_ [here, specify compensation arrangement including payment method and frequency.]

3. Contractor's Freedom to Contract. Contractor may employ assistants at its sole expense and discretion as may be necessary to fulfill Contractor's obligations under this Agreement. Contractor agrees that anyone to whom it delegates any or all of the Services called for by this contract will be competent, qualified and capable of performing the work without any supervision, contact or assistance by County's employees. Any such assistant will be employed only by Contractor, and will not be an employee of the County while performing services under this contract.

4. Expenses. County shall not be liable to Contractor for any expenses which Contractor incurs, nor shall Contractor be liable to County for office help or expenses. Contractor shall have no authority to bind County by any promise or representation, unless specifically authorized by the County Manager in writing to do so.

5. Term. This Agreement may be terminated by either party at any time upon 7 days written notice to the other party. Upon the termination of this Agreement, Contractor shall prepare and provide to County a list of all pending unfinished business involving Contractor. Contracted Services under the terms of this agreement shall terminate upon completion of the Services which shall in no event exceed 45 days for completion of the Services.

6. Nature of Relationship. Contractor understands that it is an independent contractor and is not an employee, subcontractor, agent, servant, partner nor joint venturer of County. Contractor understands that it has the right to use its best judgment and efforts to fulfill the terms and obligations of this Agreement. Contractor further understands and acknowledges the following:



- a. That it will receive no compensation other than as outlined in this Agreement and is not subject to nor eligible for any benefits which may be offered by County to its employees, such as vacation pay, sick leave, insurance coverage or retirement plan participation.
- b. Its Services provided in accordance with this Agreement are an independent calling or occupation.
- c. Contractor is expected to use its own skill, judgment and expertise to fulfill the obligations of this Agreement, and is not supervised, directed or controlled by County as to the means or methods it should employ.
- d. Contract is not required to perform tasks in any particular order or sequence.
- e. Contractor needs no training from County as to how to fulfill its duties and responsibilities.
- f. Contractor may determine its own daily schedule and those of its own employees or servants without prior approval of County.
- g. Contractor is not required to devote any particular percentage of its time or resources to perform the Services required hereunder.
- h. Contractor furnishes its own equipment and supplies and is expected to maintain its business office somewhere other than at the County's office.
- i. To the extent Contractor must procure or maintain any insurance, license, certification or trade membership, it must do so at its own cost.

j. This Agreement shall not prevent Contractor from performing other services for other parties. Contractor may engage in other business endeavors or projects of any kind or nature.

7. Taxes. Contractor assumes exclusive liability for payment of all federal, state or other governmental division taxes and contributions for social security, Medicare/Medicaid, etc., now or hereafter required, incurred or assessed by law. Contractors providing equipment, materials, parts or supplies shall provide a breakdown of labor, materials, parts or supplies and sales tax by County or a sales tax report approved by the County Finance Department with the invoice. Contractor agrees to indemnify and hold harmless the County from any claims for taxes as described in this Section.

8. Insurance. Contractor understands and agrees that neither it nor its employees are subject to workers' compensation or general liability coverage maintained by the County for its employees. Contractor agrees to procure and maintain workers' compensation insurance coverage for the benefit of contractor's employees or subcontractors and to procure general liability insurance listing the County as an additional insured at all times relevant to this Agreement. Contractor shall provide to County upon request a valid and current certificate of workers' compensation and general liability insurance. In the event Contractor shall fail at any time to have in force and effect insurance as required by this Section, Contractor agrees to indemnify and hold harmless County for (1) any premium paid by County to maintain insurance coverage applicable to Contractor and/or its employees or subcontractors; (2) any worker's compensation benefits paid by County as a result of Contractor's failure to comply with this Section; and (3) any amounts paid by County for general liability claims as a result of Contractor's failure to comply with this Section.

9. Indemnity. Contractor shall and does hereby agree to indemnify, save harmless and defend County from the payment of any sum or sums of money to any person whomsoever on account of claims or suits growing out of injuries to persons, including death, or damage to property caused by Contractor, its employees, agents or subcontractors in any way attributable to the performance of the Services, including (but without limiting the generality of the foregoing), all claims for service, labor performed, materials furnished, provisions and supplies, injuries to person or damage to property, liens, garnishments, attachments, claims, suits, costs, attorneys' fees, costs of investigation and of defense. It is the intention of this paragraph to hold the Contractor responsible for the payment of any and all claims, suits, or liens, of any nature and character, in any way attributable to or asserted against County or against Contractor and County, or which the County may be required to pay. In the event the liability of the Contractor shall arise by reason of the sole negligence of County and/or the sole negligence of County's employees, agents or servants, then and only then, Contractor shall not be liable under the provisions of this paragraph.

10. Arbitration. Any controversy or claim arising out of, or relating to this Agreement, or its breach, shall be settled by arbitration in Currituck County, North Carolina in accordance with the provisions of the North Carolina Revised Uniform Arbitration Act, (the "Act"). The parties to this Agreement understand that this arbitration provision shall expressly apply to this Agreement in accordance with the Act. Judgment upon the award rendered may be entered and enforced in any court of competent jurisdiction.

11. Notices. Any notice, request or report given by one party to the other shall be in writing, deposited in the United States Mail (postage prepaid) or hand delivered and properly addressed as follows:

If the notice is to County:

Currituck County  
Eric T. Weatherly, PE, County Engineer  
153 Courthouse Rd, Suite 302  
Currituck, NC 27929

(Or such other person or address as County shall have designated by due notice to Contractor).

If the notice is to Contractor:

\_\_\_\_\_  
\_\_\_\_\_  
\_\_\_\_\_

(Or such other person or address as Contractor shall have designated by due notice to County).

12. Non-Waiver. Nothing set forth herein is intended nor shall be construed as a waiver of any immunity available to County, its governing board or employees.

13. Headings. The headings, subheadings and captions in this Agreement and in any exhibit hereto are for reference purposes only and shall not affect the meaning or interpretation of this Agreement.

14. Amendments. This Agreement may not be amended except by written instrument duly executed by or on behalf of all of the parties hereto.

15. Complete Agreement. This Agreement constitutes the entire Agreement between County and Contractor pertaining to its subject matter and supersedes all prior and

contemporaneous negotiations, agreements and understandings of either or both parties in connection therewith.

16. Governing Law. The validity, interpretation and performance of this Agreement and of its provisions shall be governed by the laws of the State of North Carolina.

The undersigned have read the entire Agreement and accept the terms and conditions as shown by their signatures below.

**COUNTY OF CURRITUCK**

By: \_\_\_\_\_  
Attest

By: \_\_\_\_\_ (SEAL)  
Daniel F. Scanlon, II, County Manager

**CONTRACTOR**

By: \_\_\_\_\_  
Attest

By: \_\_\_\_\_ (SEAL)  
Name and Title

Independent Contractor carries and will provide County with a Certificate of Insurance for:

Workers' Compensation	Yes	No
General Liability	Yes	No

This instrument has been preaudited in the manner required by the Local Government Budget and Fiscal Control Act.

\_\_\_\_\_  
Sandra Hill, Finance Officer

## County of Currituck E-Verify Affidavit

STATE OF NORTH CAROLINA

AFFIDAVIT:  
E-VERIFY COMPLIANCE

COUNTY OF CURRITUCK

\*\*\*\*\*

I, \_\_\_\_\_ (the individual attesting below), being duly authorized by and on behalf of \_\_\_\_\_ (the entity bidding on project hereinafter "Employer") after first being duly sworn hereby swears or affirms as follows:

1. Employer understands that E-Verify is the federal E-Verify program operated by the United States Department of Homeland Security and other federal agencies, or any successor or equivalent program used to verify the work authorization of newly hired employees pursuant to federal law in accordance with NCGS §64-25(5).
2. Employer understands that Employers Must Use E-Verify. Each employer, after hiring an employee to work in the United States, shall verify the work authorization of the employee through E-Verify in accordance with NCGS§64-26(a).
3. Employer is a person, business entity, or other organization that transacts business in this State and that employs 25 or more employees in this State. (mark Yes or No)
  - a. YES \_\_\_\_\_, or
  - b. NO \_\_\_\_\_
4. Employer's subcontractors comply with E-Verify, and if Employer is the winning bidder on this project, Employer will ensure compliance by providing the County with an E-Verify Compliance Affidavit for any subcontractors current or subsequently hired by Employer.

This \_\_\_\_ day of \_\_\_\_\_, 20\_\_\_\_\_.

Signature of Affiant: \_\_\_\_\_

Print or Type Name: \_\_\_\_\_

Contractor: \_\_\_\_\_

State of \_\_\_\_\_ County of \_\_\_\_\_

Signed and sworn to (or affirmed) before me, this the \_\_\_\_ day of \_\_\_\_\_, 20\_\_.

\_\_\_\_\_  
Notary Public

My Commission Expires:

\_\_\_\_\_  
(Affix Official/Notarial Seal)

# **CONSTRUCTION NOTES**

## **GENERAL**

1. Contractor shall submit a bid for replacing an existing 24" stormwater pipe that connects two ponds and a bid for digging a new swale to connect the two ponds with a wooden footbridge. The Owner will decide which option to award after the bid opening.
2. Public safety shall be the contractor's responsibility. Adequately cordon the work area to prevent harm to the general public. Do not allow the public to walk around the construction area.
3. The contractor shall visit the site prior to bidding to determine the extent of the work. Lack of knowledge of existing conditions will not be considered a basis for change orders.
4. Contractor shall furnish and install all equipment and materials for a complete installation in all respects, ready for intended use and in strict accordance with state and local codes and manufacturer's recommendations.
5. Contractor shall comply with all OSHA regulations.
6. All bidders shall have a General Contractors license in North Carolina.
7. Construction period is 45 days.
8. Call NC One Call service at 1-800-632-4949 not less than three working days before performing work. It is the contractor's responsibility to avoid existing utility conflicts.
9. All disturbed areas shall be hand raked, smooth, and have no large objects. Reseed using 750 lbs/ac fertilizer, 2000 lbs/ac lime, 100 lbs/ac hulled common Bermuda and mulch. Reseed bare areas and repair all eroded areas for a 90 day period after initial seeding. In addition to seeding, all slopes steeper than 5:1 shall covered with jute matting in accordance with the manufacturer's specification.
10. Remove and replace existing sidewalk as necessary. New sidewalk shall be 4" thick and match existing width and location. Provide broom finish. Provide 3/4" radius on all exposed edges. Provide expansion joints every 50' and contraction joints every 10'. Place construction joints at end of pours. Concrete shall have a compressive strength of 3000 psi minimum at 28 days and slump range not greater than 3" and 5% air content (plus or minus 1.5%). Perform one slump test per load. Concrete compressive testing will not be required.

## **REPLACE EXISTING 24" STORMWATER PIPE OPTION**

### 1. Work Description

- a) A sinkhole has formed over the existing 24" CMP culvert that connects two stormwater ponds located at the Currituck County Government Center, 2793 Caratoke Highway, Currituck, NC. Work for this option is to remove the existing 24" CMP and replace it with new 24" RCP.
- b) Plans are attached for the existing culvert installation prepared by Bissell Engineering in 1991.
- c) Plans for the existing culvert indicate a ground surface elevation of 10.0' and a culvert invert elevation of 0.0'. It is estimated the existing culvert is 100' long. County staff has verified the location and depth is reasonably accurate using ground penetrating sonar equipment.
- d) The existing culvert shall be removed and disposed of.
- e) The new culvert shall be installed at the same length and invert of the existing culvert. If deflection or settlement of the existing culvert has occurred, the new culvert shall be installed as intended on the original attached plans.

### 2. Stormwater Culvert Material and Installation

- a) Pipe material shall be reinforced concrete pipe (RCP).
- b) Install pipe true to grades and alignment and in accordance to manufactures instructions.
- c) Dewatering of existing stormwater ponds is required. Well pointing may be required. The trench shall remain dry during installation.
- d) Minimum trench width shall be 48".
- e) Bottom of the trench shall be compacted, smooth and even. Place 4" of No. 57 or No. 5 stone in the entire trench for bedding under the pipe.
- f) Carefully backfill to a depth of 12" above the top of the pipe using select backfill material compacted in 6" lifts using a mechanical trench tamper to approximately 90% standard proctor density. Select backfill shall be Class II or Class III embedment materials (i.e. GP, GM, GC, SP, and SM).
- g) Native soils may be used to fill the trench from 12" above the top of the pipe to 4" below final grade. Backfill material shall be compacted in 12" lifts using a



mechanical trench tamper. Supply additional fill material as necessary to assure trench is filled to grade.

- h) Remove existing top soil prior to excavation. Use this material and additional top soil as needed for the final 4" of the trench. Final trench grade shall be level with existing grade.

## **BRIDGE OPTION**

### 1. Work Description

- a) In lieu of removing the existing culvert, the bridge option will leave the existing culvert in place and dig a new swale to connect the two existing stormwater ponds. A bridge connecting the existing sidewalk will be installed across the new swale.
- b) A swale shall be dug in the location over top of the existing culvert and shall connect the two existing stormwater ponds. The swale shall be a trapezoid shape with 4' flat bottom and 3:1 side slopes. The bottom of the swale shall be level along its length and shall be 4' deep from existing grade next to the bridge.
- c) A 20:1 slope is the maximum slope allowed by building code when approaching or leaving the footbridge.

### 2. Timber Footbridge requirements:

- a) Includes labor, materials, equipment, and incidentals necessary to construct a timber footbridge. This item shall include posts (piles), decking, guardrails, nuts, bolts, nails, cross bracing and all other items necessary to complete the bridge in accordance with the attached drawing and these specifications.
- b) All timber construction shall conform to the recommendation of the American Institute of Timber Construction.
- c) Pilings shall be 6" x 6". Deck board shall be 2" x 6" - #1 radius edge deck board. All fasteners shall be galvanized.
- d) REVISION TO THE PLANS, ALL JOISTS SHALL BE 2"x8".
- e) Minimum pile bury depth shall be 8'. Piles may be driven, washed in or placed in an augured hole with concrete backfill. The contractor may submit other methods for use if submitted with an engineer's stamp of approval.
- f) All pilings shall have CCA preservation with retention of 2.50 pcf. All other timber shall have CCA preservation with retention 0.6 pcf.



Currituck County  
Government Center Complex  
2793 Caratoke Highway

Culvert location

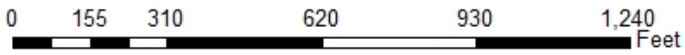

Site Map



Existing Sidewalk

Pond A

Existing 24" CMP to be replaced with 24" RCP

Pond B

Dewatering outlet

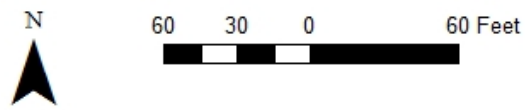

Site Plan

# Original Construction Drawing

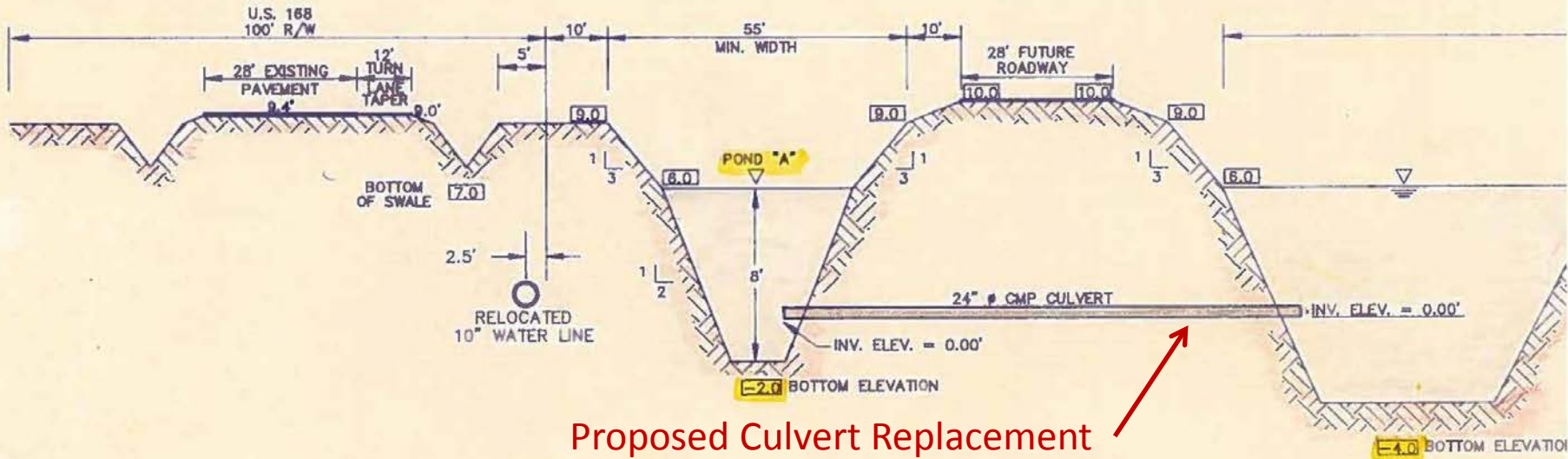

Proposed Culvert Replacement

STATION 2+64

ROADWAY/PONDS/ISLAND/CAUSEWAY/CROSS S

SECTION D-D SHEET C-2

N.T.S.

# Original Construction Drawing

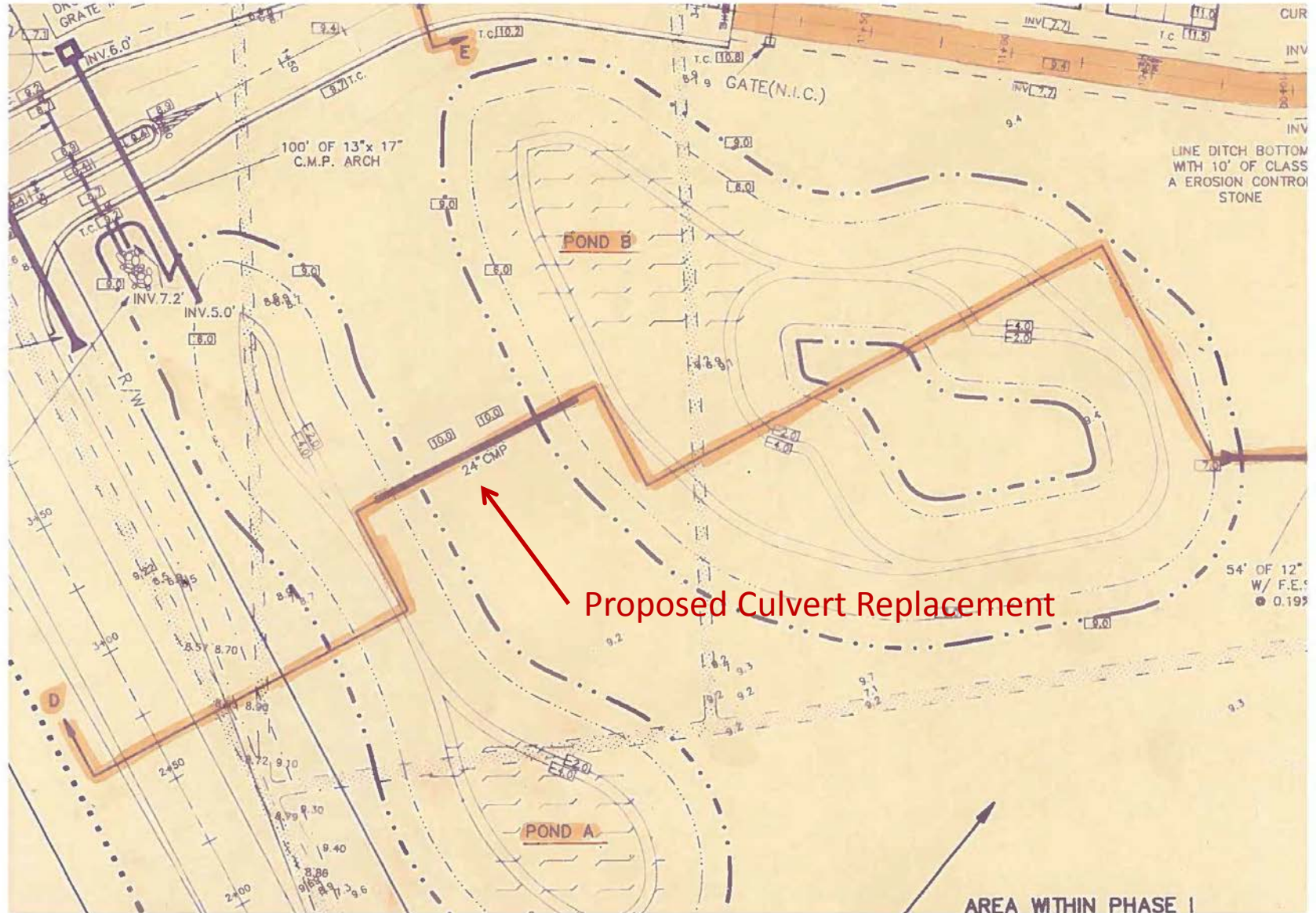

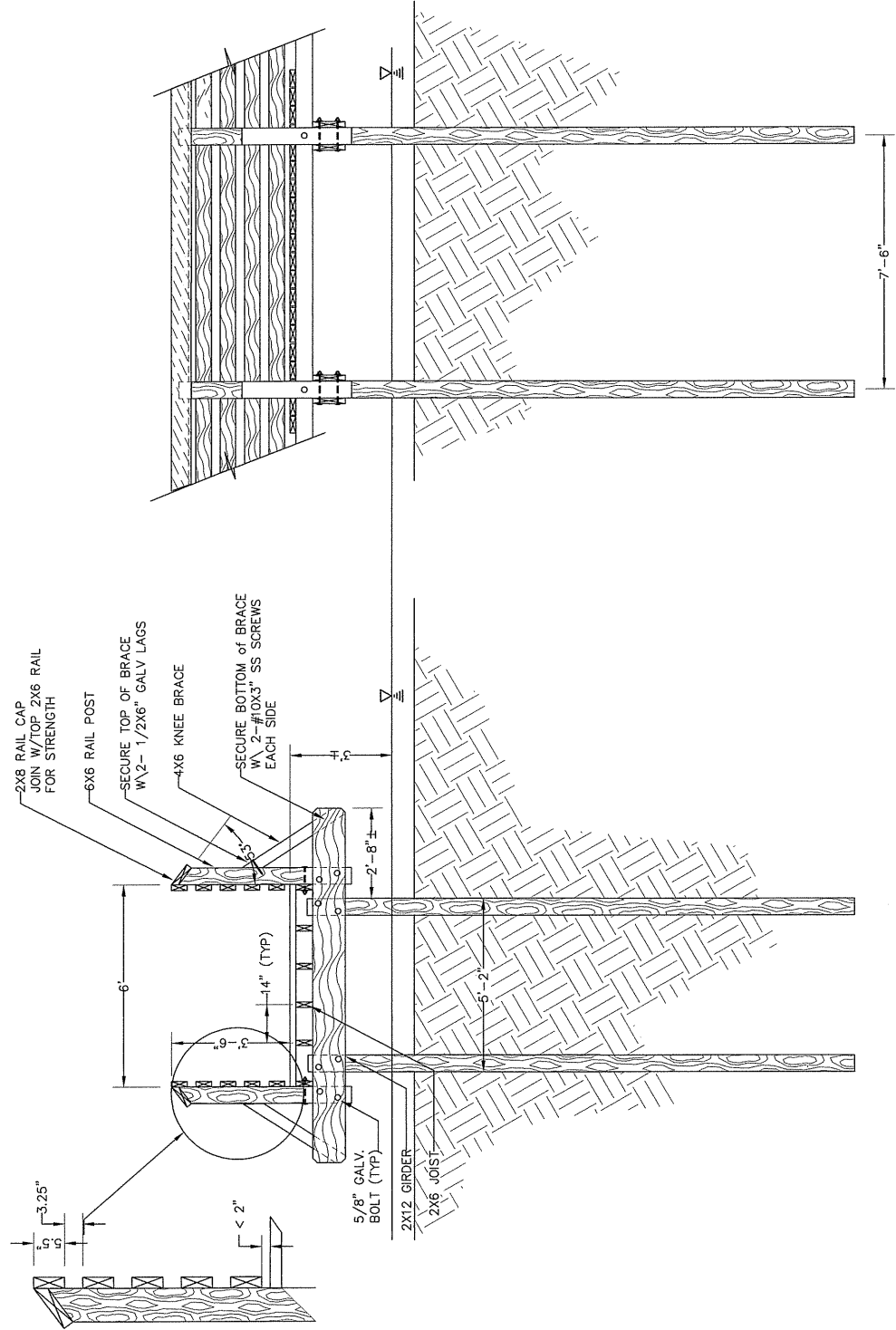
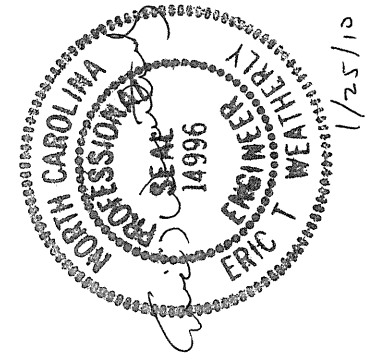

SECTION B

SECTION A

Planning  
 Design - Construction  
 Project Management  
 113 B Street, Suite 206  
 Raleigh, NC 27601  
 919-833-1111  
 www.lsl.com

CURRITUCK GOVERNMENT CENTER, CURRITUCK, CURRITUCK CO., NORTH CAROLINA  
 CURRITUCK COUNTY  
**TIMBER FOOTBRIDGE**

DATE	1/2/11
DESIGN BY	1/2/11
DRAWN BY	
APPROVED BY	
SHEET	1 OF 2
PROJ. #	

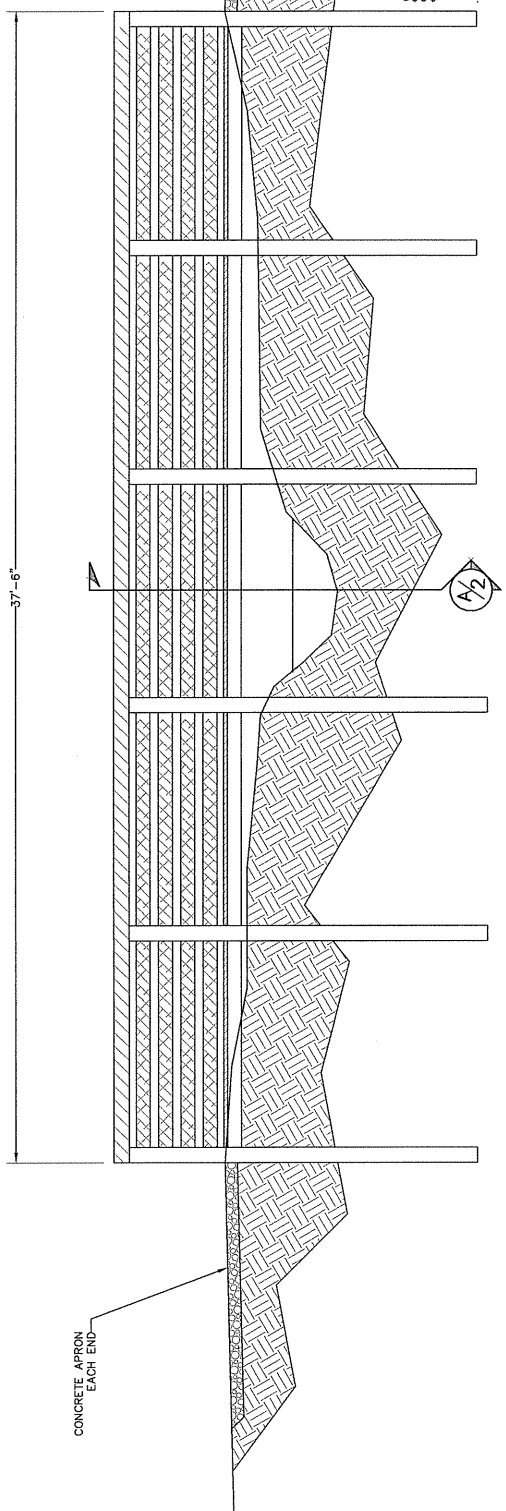
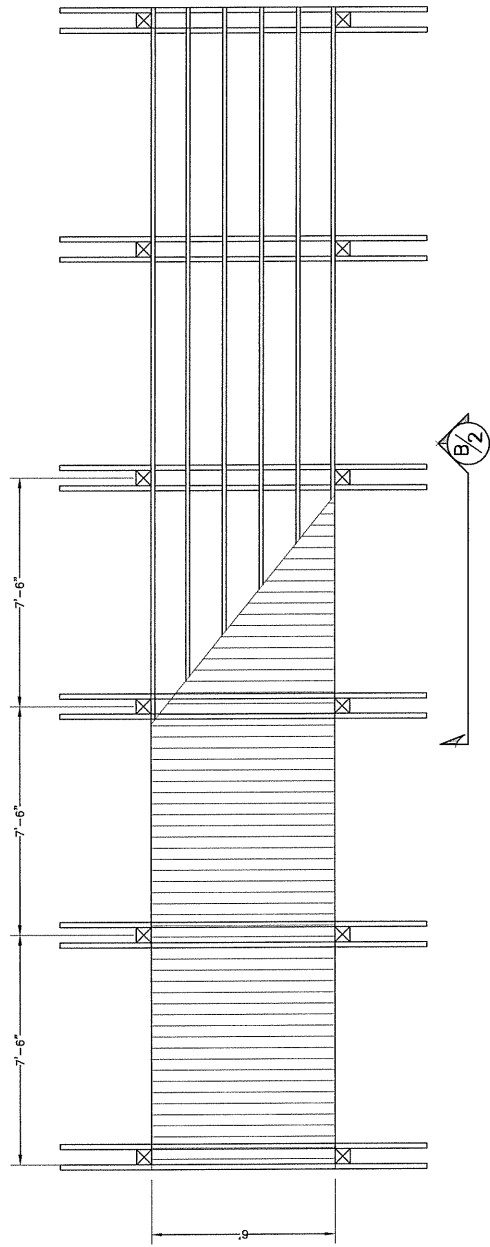

c/152/1  
 PROFESSIONAL SEAL  
 14996  
 ENGINEER  
 ERIC T. WEAVER  
 NORTH CAROLINA