



Currituck Planning & Community Development Department Guidelines for Residential Decks



WHY DO YOU NEED A BUILDING PERMIT AND INSPECTIONS?

To ensure that the deck will comply with local zoning regulations and the North Carolina State Residential Building Code. The county zoning regulations establish minimum setbacks that must be maintained from property lines. The building code governs the method of construction, materials, means of support, attachment and may require safety features such as guard rails and handrails. See the attachment "Appendix M Wood Decks", from the 2018 Residential Building Code for building code information.

You may also be required to install a new electrical outlet when you build a deck: THE NATIONAL ELECTRICAL CODE REQUIRES THAT ALL BALCONIES, DECKS, AND PORCHES THAT ARE ACCESSIBLE FROM INSIDE THE DWELLING UNIT HAVE AT LEAST ONE GFCI WEATHER RESISTANT RECEPTACLE OUTLET INSTALLED WITHIN THE PERIMETER OF THE BALCONY, DECK, OR PORCH. THE RECEPTACLE SHALL NOT BE LOCATED MORE THAN 6 1/2 FT ABOVE THE BALCONY, DECK, OR PORCH SURFACE.

APPENDIX M

WOOD DECKS

This appendix is a North Carolina addition and not part of the 2015 *International Residential Code*.
There will be no underlined text.

(The provisions contained in this appendix are adopted as part of this code.)

SECTION AM101 GENERAL

AM101.1 General. A deck is an exposed exterior wood floor that is permitted to be attached to the structure or minimum footing in accordance with Figure AM102.1(1) and freestanding. Roofed porches (open or screened-in) are permitted to be constructed using these provisions.

AM101.2 Deck design. Computer deck design programs are permitted to be accepted by the code official.

SECTION AM102 FOOTINGS

AM102.1 Footings. Support posts shall be supported by a structure that is permitted to be attached to the structure or minimum footing in accordance with Figure AM102.1(1) and freestanding. Roofed porches (open or screened-in) are permitted to be constructed using these provisions. Table AM102.1. Minimum footing depth shall be 12 inches (305 mm) below finished grade in accordance with Section R403.1.4. Tributary area is calculated as shown in Figure AM102.1(2).

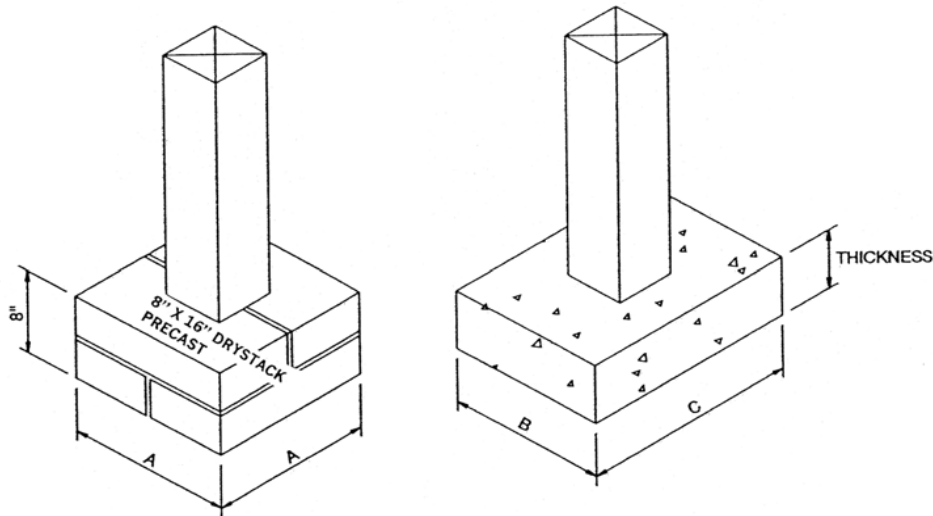

FIGURE AM102.1(1)
SUPPORT POST FOOTING

TABLE AM102.1
FOOTING TABLE^{a, b, c}

SIZE (inches)		TRIBUTARY AREA (square feet)	THICKNESS (inches)	
A x A	B x C		Precast	Cast-In-Place
8 x 16	8 x 16	36	4	6
12 x 12	12 x 12	40	4	6
16 x 16	16 x 16	70	8	8
—	16 x 24	100	—	8
—	24 x 24	150	—	8

For SI: 1 inch = 25.4 mm, 1 square foot = 0.0929 m².

- a. Footing values are based on single floor and roof loads.
- b. Support post must rest in center one-third of footing.
- c. Top of footing shall be level for full bearing support of post.

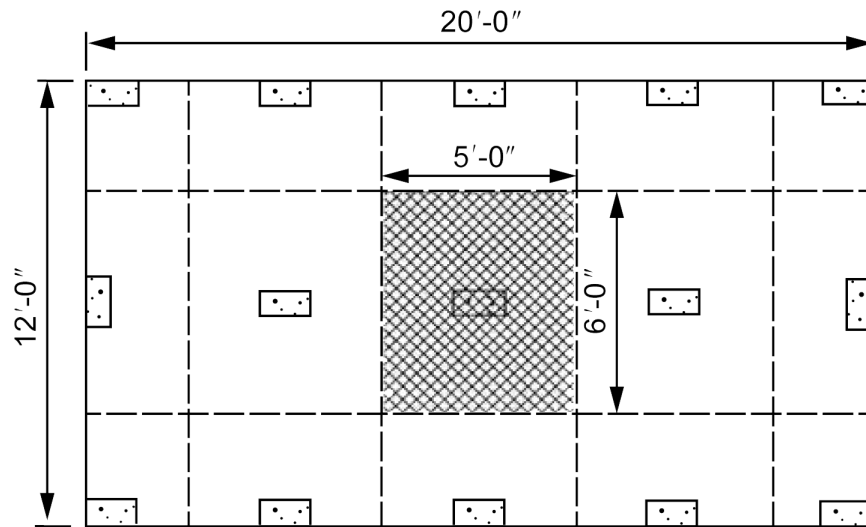

For SI: 1 inch = 25.4 mm, 1 square foot = 0.0929 m².

Note: Tributary area of shaded section on the free standing deck shown is 5' × 6' = 30 square feet (2.79 m²). Code will require a minimum footing of 8" × 16" (203 mm × 406 mm) in accordance with Table AM102.1.

**FIGURE AM102.1(2)
CALCULATED TRIBUTARY AREA**

**SECTION AM103
FLASHING**

AM103.1 Flashing. When attached to a structure, the structure to which it is attached shall have a treated wood band for the length of the deck, or corrosion-resistant flashing shall be used to prevent moisture from coming in contact with the untreated framing of the structure. Aluminum flashing shall not be used in conjunction with deck construction. The deck band and the structure band shall be constructed in contact with each other except on brick veneer structures and where plywood sheathing is required and properly flashed. Siding shall not be installed between the structure and the deck band. If attached to a brick structure, neither the flashing nor a treated band for brick structure is required. In addition, the treated deckband shall be constructed in contact with the brick veneer. Flashing shall be installed in accordance with Figure AM103.1.

**SECTION AM104
DECK ATTACHMENT**

AM104.1 Deck attachment. When a deck is supported at the structure by attaching the deck to the structure, Tables AM104.1(1) and AM104.1(2) shall apply for attaching the deck band to the structure.

AM104.1.1 Masonry ledge support. If the deck band is supported by a minimum of 1/2 inch (13 mm) masonry ledge along the foundation wall, 5/8-inch (16 mm) hot-dip galvanized bolts with washers spaced at 48 inches (1219 mm) o.c. are permitted to be used for support.

AM104.1.2 Other means of support. Joist hangers or other means of attachment are permitted to be connected to the house band and shall be properly flashed.

**SECTION AM105
GIRDER SUPPORT AND SPAN**

AM105.1 General. Girders shall bear directly on the support post with the post attached at top to prevent lateral displacement or be connected to the side of the posts with two 5/8-inch (16 mm) hot-dip galvanized bolts with nut and washer. Girder support is permitted to be installed in accordance with Figure AM105.1(1) for top mount; Figure AM105.1(2) for side mount and Figure AM105.1(3) for split girders. See Figure AM105.1(4) for cantilevered girders.

AM105.2 Girder span for uncovered porches and decks. Maximum allowable spans for wood deck girders, as shown in Figure AM105.2, shall be in accordance with Table AM105.2. Girder plies shall be fastened with two rows of 10d (3-inch × 0.128-inch) nails minimum at 16 inches (406 mm) on center along each edge. Girders shall be permitted to cantilever at each end up to one-fourth of the actual beam span. Splices of multispan beams shall be located at interior post locations.

AM105.3 Girder span for roofed porches and decks. Girder spans for covered decks shall be in accordance with Tables R602.7(1) and (2).

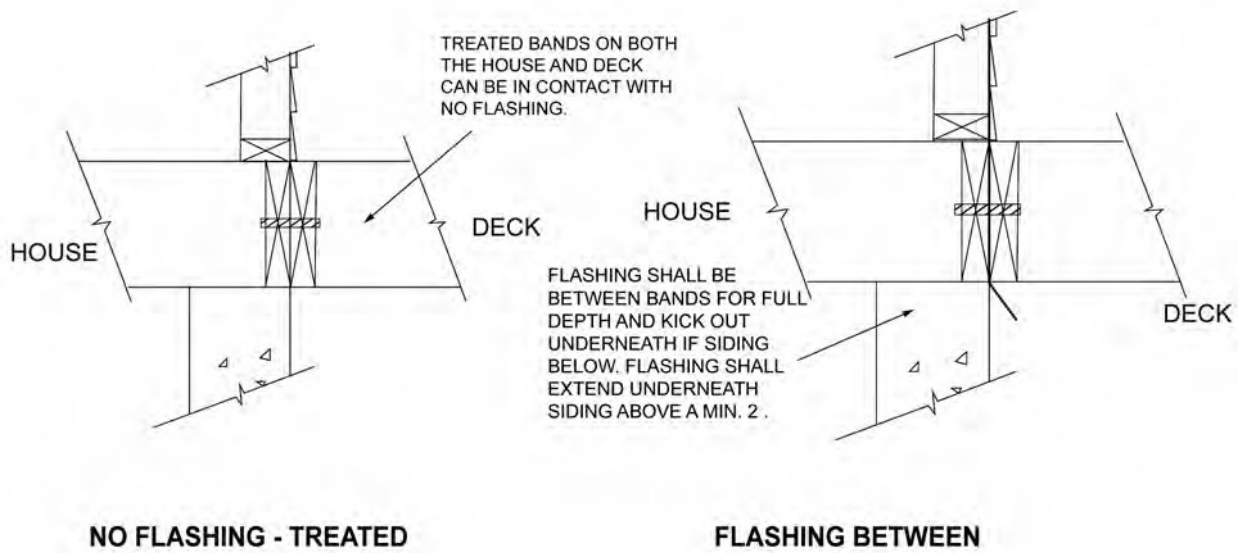

For SI: 1 inch = 25.4 mm

**FIGURE AM103.1
FLASHING FOR DECK ATTACHED TO STRUCTURE**

**TABLE AM104.1(1)
DECK ATTACHMENT FOR ALL STRUCTURES EXCEPT BRICK VENEER**

FASTENERS	8' MAX JOIST SPAN ^a	16' MAX JOIST SPAN ^a
$\frac{5}{8}$ " Hot-dip galvanized bolts with nut and washer ^b and 12d Common hot-dip galvanized nails ^c	1 @ 3'-6" o.c. and 2 @ 8" o.c.	1 @ 1'-8" o.c. and 3 @ 6" o.c.
OR		
Self-drilling screw fastener ^d	12" o.c. staggered	6" o.c. staggered

For SI: 1 inch = 25.4, 1 foot = 304.8 mm

- a. Attachment interpolation between 8 foot and 16 foot joists span is allowed.
- b. Minimum edge distance for bolts is 2½ inches.
- c. Nails must penetrate the supporting structure band a minimum of 1½ inches.
- d. Self-drilling screw fastener having a minimum shank diameter of 0.195 inches and a length long enough to penetrate through the supporting structure band. The structure band shall have a minimum depth of 1⅛ inches. Screw shall be evaluated by an approved testing agency for allowable shear load for Southern Pine to Southern Pine lumber of 250 pounds and shall have a corrosion-resistant finish equivalent to hot dip galvanized. Minimum edge distance for screws is 1⅞ inches. A maximum of ½ inch thick wood structural panel is permitted to be located between the deck ledger and the structure band.

**TABLE AM104.1(2)
DECK ATTACHMENT FOR BRICK VENEER STRUCTURES**

FASTENERS	8' MAX JOIST SPAN ^a	16' MAX JOIST SPAN ^a
$\frac{5}{8}$ " Hot-dip galvanized bolts with nut and washer ^b	1 @ 2'-4" o.c.	1 @ 1'-4" o.c.

For SI: 1 inch = 25.4, 1 foot = 304.8 mm.

- a. Attachment interpolation between 8 foot and 16 foot joist span is allowed.
- b. Minimum edge distance for bolts is 2½ inches.

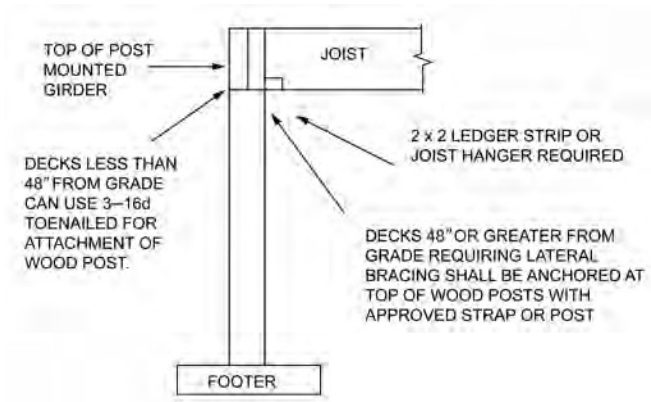

For SI: 1 inch = 25.4 mm.

**FIGURE AM105.1(1)
TOP MOUNT/FLUSH GIRDER**

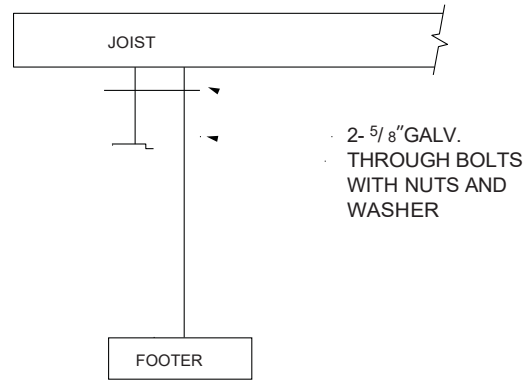

For SI: 1 inch = 25.4 mm

**FIGURE AM105.1(2)
SIDE MOUNT DROPPED GIRDER**

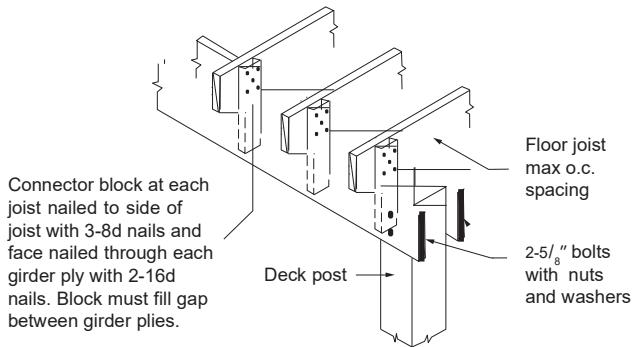

split girder limited to floor loads only and cantilever girder ends allowed per AM105.1(4).

For SI: 1 inch = 25.4 mm.

**FIGURE AM105.1(3)
SPLIT GIRDER**

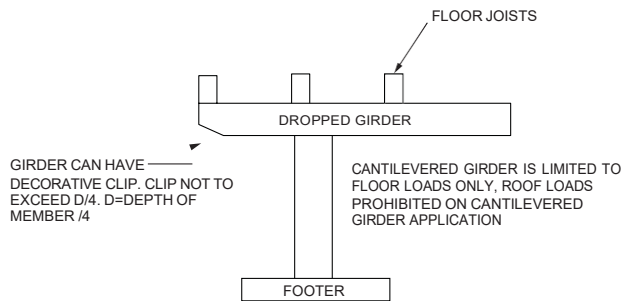

For SI: 1 inch = 25.4 mm.

**FIGURE AM105.1(4)
CANTILIEVERED DROPPED GIRDER**

**SECTION AM106
JOIST SPANS AND CANTILEVERS**

AM106.1 Joist spans for uncovered porches and decks. Maximum allowable spans for wood deck joists, as shown in Figure AM106.1, shall be in accordance with Table AM106.1. Deck joists shall be permitted to cantilever not greater than one-fourth of the actual, adjacent joist span.

AM106.1.1 Lateral restraint at supports. Joist ends and bearing locations shall be provided with lateral restraint to prevent rotation. Where lateral restraint is provided by

joist hangers or blocking between joists, their depth shall equal not less than 60 percent of the joist depth. Where lateral restraint is provided by rim joists, they shall be secured to the end of each joist with not less than (3) 10d (3-inch × 0.128-inch) nails or (3) No. 10 × 3-inch (76 mm) long wood screws.

AM106.2. Roofed porches and decks. Joists spans shall be in accordance with Table R502.3.1(2) with 40-pounds per-square-foot live load and 10-pounds per-square-foot dead load. Cantilevered floor joists shall be in accordance with Table R502.3.3(1).

**TABLE AM105.2
DECK GIRDER SPAN LENGTHS^{a, b}
(feet – inches)**

SPECIES ^c	SIZE ^d	DECK JOIST SPAN LESS THAN OR EQUAL TO: (feet)						
		6	8	10	12	14	16	18
Southern pine	2 – 2 × 6	6-11	5-11	5-4	4-10	4-6	4-3	4-0
	2 – 2 × 8	8-9	7-7	6-9	6-2	5-9	5-4	5-0
	2 – 2 × 10	10-4	9-0	8-0	7-4	6-9	6-4	6-0
	2 – 2 × 12	12-2	10-7	9-5	8-7	8-0	7-6	7-0
	3 – 2 × 6	8-2	7-5	6-8	6-1	5-8	5-3	5-0
	3 – 2 × 8	10-10	9-6	8-6	7-9	7-2	6-8	6-4
	3 – 2 × 10	13-0	11-3	10-0	9-2	8-6	7-11	7-6
Douglas fir-larch ^e , hem-fir ^e , spruce-pine-fir ^e , redwood, western cedars, ponderosa pine ^f , red pine ^f	3 × 6 or 2 – 2 × 6	5-5	4-8	4-2	3-10	3-6	3-1	2-9
	3 × 8 or 2 – 2 × 8	6-10	5-11	5-4	4-10	4-6	4-1	3-8
	3 × 10 or 2 – 2 × 10	8-4	7-3	6-6	5-11	5-6	5-1	4-8
	3 × 12 or 2 – 2 × 12	9-8	8-5	7-6	6-10	6-4	5-11	5-7
	4 × 6	6-5	5-6	4-11	4-6	4-2	3-11	3-8
	4 × 8	8-5	7-3	6-6	5-11	5-6	5-2	4-10
	4 × 10	9-11	8-7	7-8	7-0	6-6	6-1	5-8
	4 × 12	11-5	9-11	8-10	8-1	7-6	7-0	6-7
	3 – 2 × 6	7-4	6-8	6-0	5-6	5-1	4-9	4-6
	3 – 2 × 8	9-8	8-6	7-7	6-11	6-5	6-0	5-8
	3 – 2 × 10	12-0	10-5	9-4	8-6	7-10	7-4	6-11
	3 – 2 × 12	13-11	12-1	10-9	9-10	9-1	8-6	8-1

For SI: 1 inch = 25.4 mm, 1 foot = 304.8 mm, 1 pound per square foot = 0.0479 kPa, 1 pound = 0.454 kg.

- a. Ground snow load, live load = 40 psf, dead load = 10 psf, L/Δ = 360 at main span, L/Δ = 180 at cantilever with a 220-pound point load applied at the end.
- b. Girders supporting deck joists from one side only.
- c. No. 2 grade, wet service factor.
- d. Girder depth shall be greater than or equal to depth of joists with a flush beam condition.
- e. Includes incising factor.
- f. Northern species. Incising factor not included.

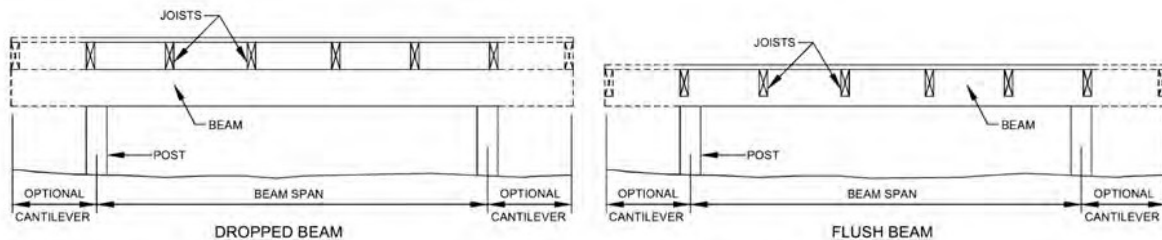

**FIGURE AM105.2
TYPICAL DECK GIRDER SPANS**

**TABLE AM106.1
DECK JOIST SPANS FOR COMMON LUMBER SPECIES^f
(feet – inches)**

SPECIES ^a	SIZE	SPACING OF DECK JOISTS WITH NO CANTILEVER ^b (inches)			SPACING OF DECK JOISTS WITH CANTILEVERS ^c (inches)		
		12	16	24	12	16	24
Southern pine	2 × 6	9-11	9-0	7-7	6-8	6-8	6-8
	2 × 8	13-1	11-10	9-8	10-1	10-1	9-8
	2 × 10	16-2	14-0	11-5	14-6	14-0	11-5
	2 × 12	18-0	16-6	13-6	18-0	16-6	13-6
Douglas fir-larch ^d , hem-fir ^d , spruce-pine-fir ^d	2 × 6	9-6	8-8	7-2	6-3	6-3	6-3
	2 × 8	12-6	11-1	9-1	9-5	9-5	9-1
	2 × 10	15-8	13-7	11-1	13-7	13-7	11-1
	2 × 12	18-0	15-9	12-10	18-0	15-9	12-10
Redwood, western cedars, ponderosa pine ^e , red pine ^e	2 × 6	8-10	8-0	7-0	5-7	5-7	5-7
	2 × 8	11-8	10-7	8-8	8-6	8-6	8-6
	2 × 10	14-11	13-0	10-7	12-3	12-3	10-7
	2 × 12	17-5	15-1	12-4	16-5	15-1	12-4

For SI: 1 inch = 25.4 mm, 1 foot = 304.8 mm, 1 pound per square foot = 0.0479 kPa, 1 pound = 0.454 kg.

- a. No. 2 grade with wet service factor.
- b. Ground snow load, live load = 40 psf, dead load = 10 psf, L/Δ = 360.
- c. Ground snow load, live load = 40 psf, dead load = 10 psf, L/Δ = 360 at main span, L/Δ = 180 at cantilever with a 220-pound point load applied to end.
- d. Includes incising factor.
- e. Northern species with no incising factor.
- f. Cantilevered spans not exceeding the nominal depth of the joist are permitted.

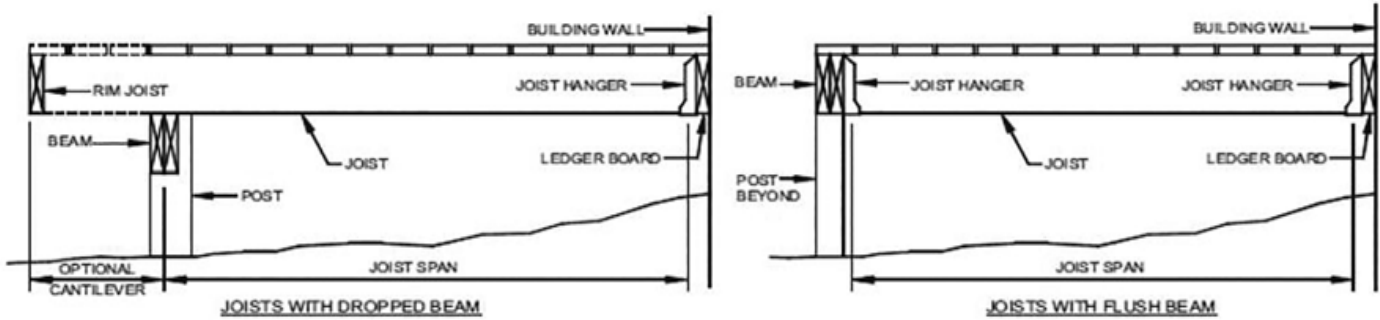

**FIGURE AM106.1
TYPICAL DECK JOIST SPANS**

**SECTION AM107
FLOOR DECKING**

AM107.1 Floor decking. Floor decking shall be No. 2 grade treated Southern Pine or equivalent. The minimum floor decking thickness shall be in accordance with Table AM107.1.

**TABLE AM107.1
FLOOR DECKING THICKNESS**

SPACING	DECKING (nominal)
12" o.c.	1" S4S
16" o.c.	1" T&G
19.2" o.c.	1 1/4" S4S
24"-36" o.c.	2" S4S

For SI: 1 inch = 25.4, 1 foot = 304.8 mm.

**SECTION AM108
POST HEIGHT**

AM108.1 Post height. Maximum height of deck supportposts shall be in accordance with Table AM108.1.

**TABLE AM108.1
DECK SUPPORT POST HEIGHT**

POST SIZE ^a	MAXIMUM POST HEIGHT ^{b, c}
4" × 4"	8'-0"
6" × 6"	20'-0"

For SI: 1 inch = 25.4, 1 foot = 304.8 mm.

- a. This table is based on No. 2 Southern Pine posts.
- b. From top of footing to bottom of girder.
- c. Decks with post heights exceeding these requirements shall be designed by a registered design professional.

**SECTION AM109
DECK BRACING**

AM109.1 Deck bracing. Decks shall be braced to provide lateral stability. Lateral stability shall be provided in accordance with one of the methods in Sections AM109.1.1 through AM109.1.5.

AM109.1.1 Lateral bracing not required. When the deck floor height is less than 4 feet (1219 mm) above finished grade as shown in Figure AM109.1(1) and the deck is attached to the structure in accordance with Section AM104, lateral bracing is not required. Lateral bracing is not required for freestanding decks with a deck floor height 30 inches (762 mm) or less above finished grade.

AM109.1.2. Knee bracing. 4 × 4 wood knee braces are permitted to be provided on each column in both directions. The knee braces shall attach to each post at a point not less than 1/3 of the post length from the top of the post, and the braces shall be angled between 45 degrees (0.79 rad) and 60 degrees (1.05 rad) from the horizontal. Knee braces shall be bolted to the post and the girder/double band with one 5/8-inch (16 mm) hot-dip galvanized bolt with nut and washer at both ends of the brace as shown in Figure AM109.1(2)

AM109.1.3. Post embedment. For free standing decks without knee braces or diagonal bracing, lateral stability is permitted to be provided by embedding the post in accordance with Figure AM109.1(3) and Table AM109.1.

**TABLE AM109.1
POST EMBEDMENT FOR FREE STANDING DECKS**

POST SIZE	MAXIMUM TRIBUTARY AREA	MAXIMUM POST HEIGHT	EMBEDMENT DEPTH	CONCRETE DIAMETER
4" × 4"	48 SF	4'-0"	2'-6"	1'-0"
6" × 6"	120 SF	6'-0"	3'-6"	1'-8"

For SI: 1 inch = 25.4 mm, 1 square foot = 0.0929 m².

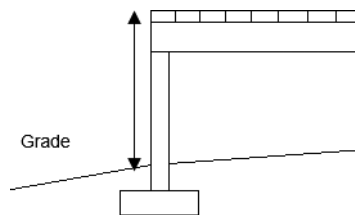

Less than 4' (decking to grade) and attached to structure no bracing required

For SI: 1 inch = 25.4, 1 foot = 304.8 mm.

**FIGURE AM109.1(1)
NO LATERAL BRACING**

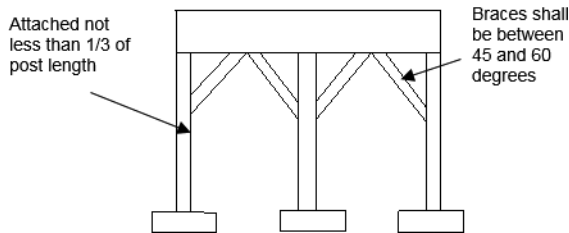
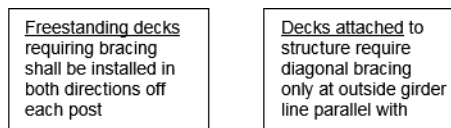

For SI: 1 inch = 25.4, 1 foot = 304.8 mm.

**FIGURE AM109.1(2)
KNEE BRACING**

AM109.1.4. Cross bracing. 2 × 6 diagonal vertical cross bracing is permitted to be provided in two perpendicular directions for free standing decks or parallel to the structure at the exterior column line for attached decks. The 2 × 6 bracing shall be attached to the posts with one 5/8-inch (16 mm) hot-dip galvanized bolt with nut and washer at each end of each bracing member in accordance with Figure AM109.1(4).

AM109.1.5. Piles in coastal regions. For embedment of piles in coastal regions, see Chapter 46.

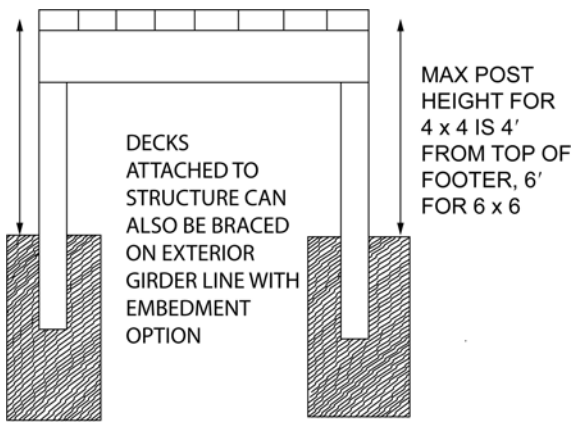

For SI: 1 inch = 25.4, 1 foot = 304.8 mm.

**FIGURE AM109.1(3)
POST EMBEDMENT**

**SECTION AM110
STAIRS**

AM110.1 Stair construction. Stringer spans shall be no greater than 7 feet (2134 mm) between supports. Spacing between stringers shall be based upon decking material used in accordance with AM107.1. Each stringer shall have a minimum of 3 1/2 inches (89 mm) between step cut and back of stringer. If used, suspended headers shall be attached with 3/8-inch (9.5 mm) galvanized bolts with nuts and washers to securely support stringers at the top. See Figure AM 110.1.

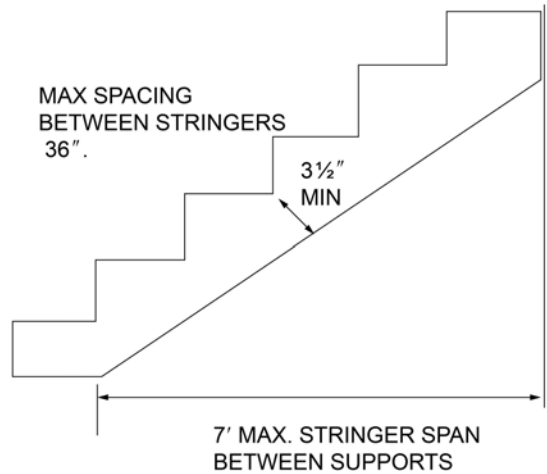

For SI: 1 inch = 25.4, 1 foot = 304.8 mm.

**FIGURE AM110.1
STAIR STRINGER**

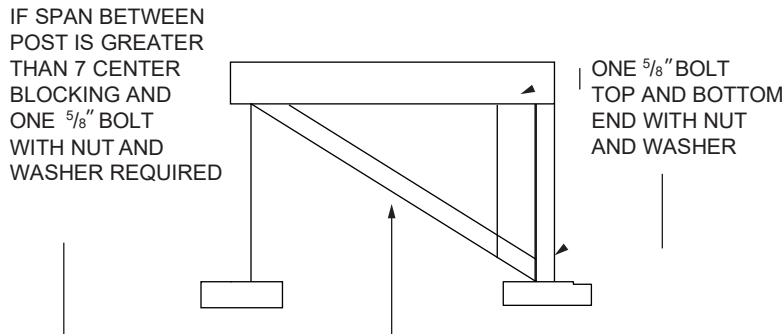

For SI: 1 inch = 25.4, 1 foot = 304.8 mm.

**FIGURE AM109.1(4)
CROSS BRACING**

**SECTION AM111
HANDRAILS, GUARDS AND GENERAL**

AM111.1 Handrails, guards and general. Deck handrails, guards and general construction shall be as shown in Figure AM111.1.

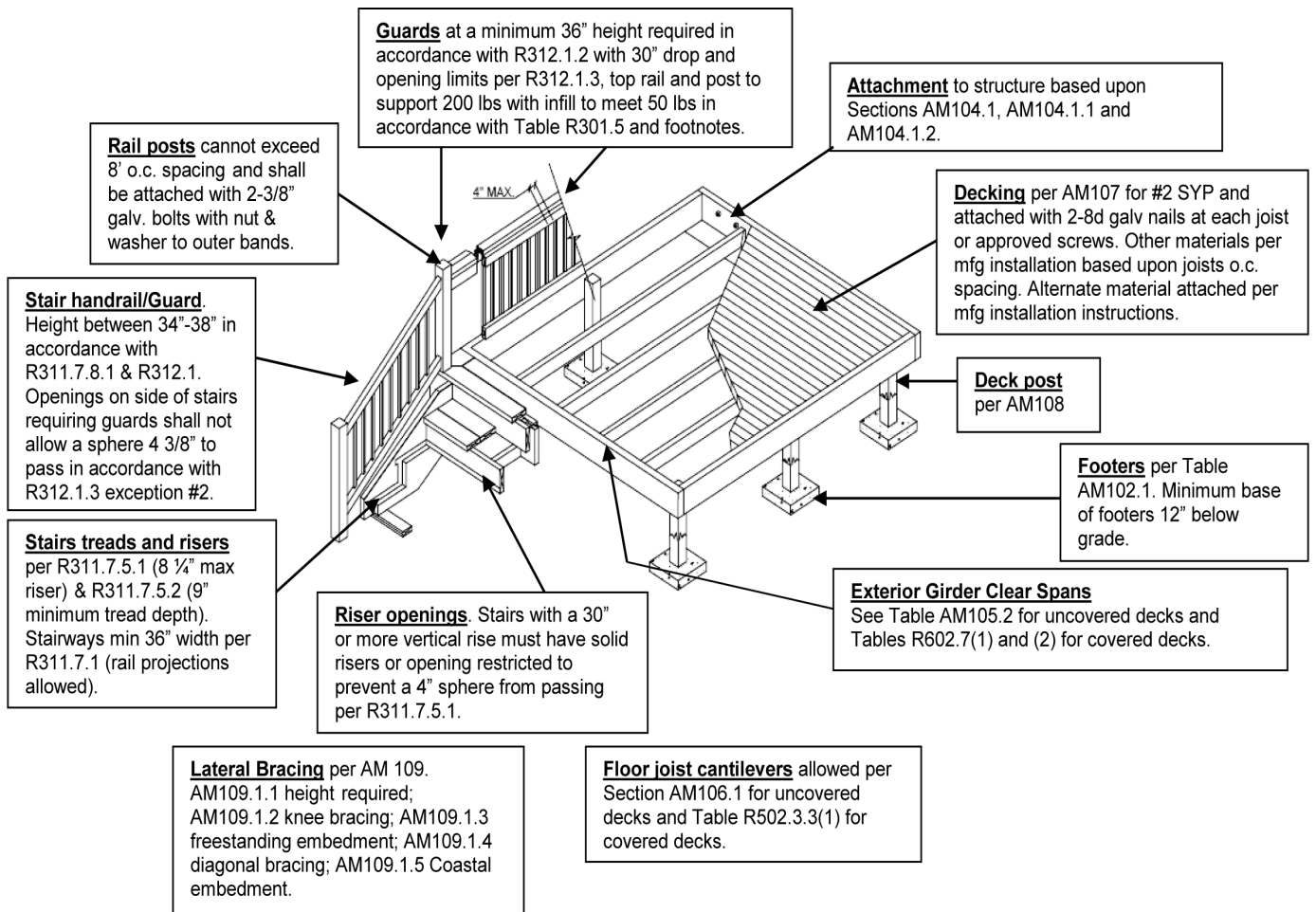

For SI: 1 inch = 25.4, 1 foot = 304.8 mm.

**FIGURE AM111.1
DECK CONSTRUCTION**

**SECTION AM112
WALKWAYS IN OCEAN HAZARD AREAS**

AM112.1 Walkways over dunes. Walkways over dunes in ocean hazard areas shall be constructed as shown in Figure AM112.1.

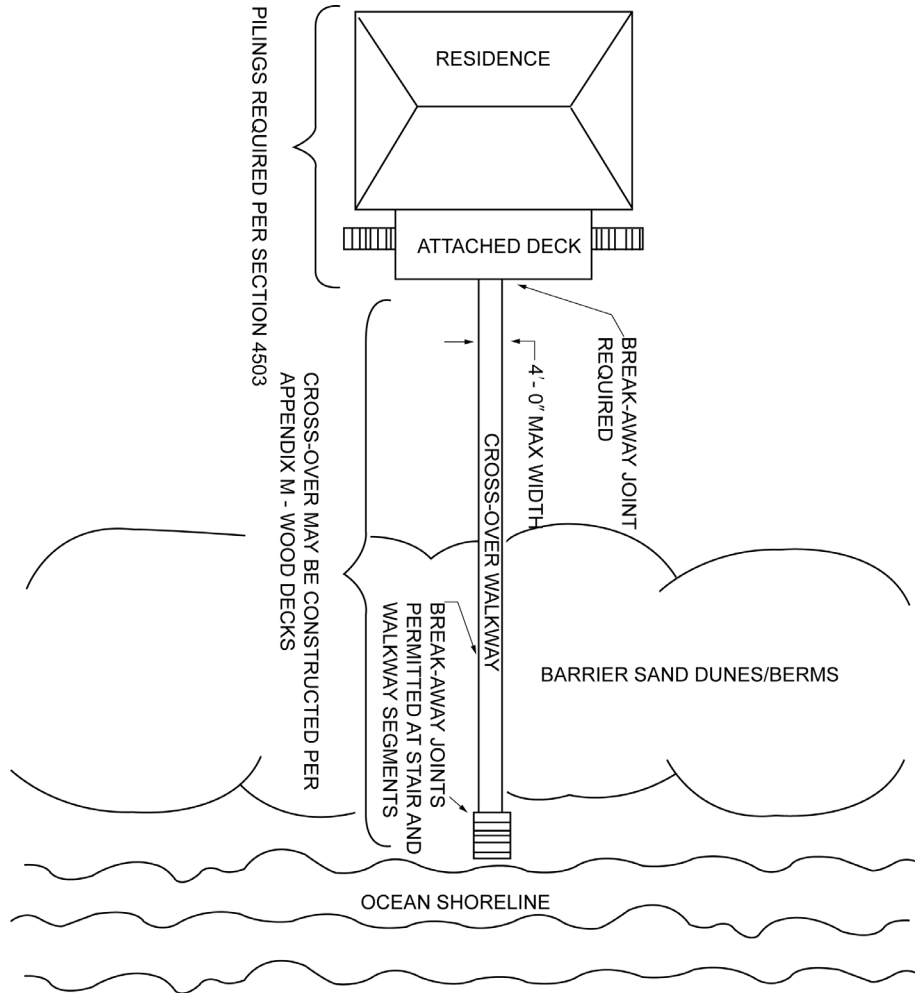

For SI: 1 inch = 25.4, 1 foot = 304.8 mm.

- * Posts for walkways over dunes or berms shall be embedded a minimum depth of 4' - 0" and post heights shall be limited to 5'- 0" above grade for 4 × 4 and 10' - 0" above grade for 6 × 6. Walkways or portions of walkways over 4' 0" in width shall comply with the requirements of Chapters 45 and 46. Maximum walkway surface height is 30" above grade without guard rails.
- ** Walkway stair runs are permitted to be greater than 12' without a landing.
- *** Open risers permitted on ocean shoreline stair.
- **** Horizontal guards permitted to have maximum 18 inch opening on cross-over walkway and ocean shoreline stair.

**FIGURE AM112.1
WALKWAYS OVER DUNES OR BERMS IN OCEAN HAZARD AREAS**